



Ordering Information

Wall Mount Hydra-Clean Package

Package Order No.	247550	247552	247554	258665	Pump Package
Air Motor Part No.	N34DN0	N65DN0	N65DN0	N65DN0	
Pump Lower Part No.	247599	241648	687055	24B923	
Pump Construction	SST	SST	SST	SST	
Standard Seal Repair Kit	247881	222880	See manual 311825	24C162	
Standard Seal Construction	PTFE/ CF-PTFE	UHMWPE/ CF-PTFE	UHMWPE/ CF-PTFE	UHMWPE/ CF-PTFE	
Optional Seal Repair Kits	207581	222875	222845	237713	
Optional Seal Construction	PTFE	UHMWPE/PTFE	UHMWPE/PTFE	UHMWPE/PTFE	
Flyer	338026	338026	338026	338026	
Instruction Manual	312585	312585	312585	312585	



Cart Mount Hydra-Clean Package

Package Order No.	247549	247551	247553	258664	Pump Package
Air Motor Part No.	N34DN0	N65DN0	N65DN0	N65DN0	
Pump Lower Part No.	247599	241648	687055	24B923	
Pump Construction	SST	SST	SST	SST	
Standard Seal Repair Kit	247881	222880	See manual 311825	24C162	
Standard Seal Construction	PTFE/ CF-PTFE	UHMWPE/ CF-PTFE	UHMWPE/ CF-PTFE	UHMWPE/ CF-PTFE	
Optional Seal Repair Kits	207581	222875	222845	237713	
Optional Seal Construction	PTFE	UHMWPE/PTFE	UHMWPE/PTFE	UHMWPE/PTFE	
Flyer	338026	338026	338026	338026	
Instruction Manual	312585	312585	312585	312585	



Drum Mount Hydra-Clean Package

Package Order No.	206515	Pump Package
Air Motor Part No.	207352	
Pump Lower Part No.	224344	
Pump Construction	SST	
Standard Seal Repair Kit	224402	
Standard Seal Construction	UHMWPE/Polychloroprene	
Optional Seal Repair Kit	224889	
Optional Seal Construction	PTFE	
Instruction Manual	306817	



Hydra-Clean Pressure Washers

Technical Specifications

Part Number	Pump Package	Max. Working Pressure psi (bar, MPa)	Max. Air Input Pressure psi (bar, MPa)	Fluid Flow at 60 cpm gpm (lpm)	Vol. per Cycle oz (cc)	Air Inlet Size	Fluid Inlet Size	Fluid Outlet Size*	Flyer	Manual
247549	12:1 Cart Mount	1250 (86, 8.6)	100 (7, 0.7)	8.7 (33.0)	18.6 (550)	3/4 npt(f)	1 in	3/8 in	338026	312585
247550	12:1 Wall Mount	1250 (86, 8.6)	100 (7, 0.7)	8.7 (33.0)	18.6 (550)	3/4 npt(f)	1 in	3/8 in	338026	312585
247551	23:1 Cart Mount	2275 (157, 15.7)	100 (7, 0.7)	9.2 (34.7)	19.6 (580)	3/4 npt(f)	1 in	3/8 in	338026	312585
247552	23:1 Wall Mount	2275 (157, 15.7)	100 (7, 0.7)	9.2 (34.7)	19.6 (580)	3/4 npt(f)	1 in	3/8 in	338026	312585
247553	30:1 Cart Mount	3065 (211, 21.1)	100 (7, 0.7)	6.8 (25.9)	14.5 (430)	3/4 npt(f)	1 in	3/8 in	338026	312585
247554	30:1 Wall Mount	3065 (211, 21.1)	100 (7, 0.7)	6.8 (25.9)	14.5 (430)	3/4 npt(f)	1 in	3/8 in	338026	312585
258664	40:1 Cart Mount	4000 (275, 27.5)	100 (7, 0.7)	4.6 (17.4)	9.8 (290)	3/4 npt(f)	1 in	3/8 in	338026	312585
258665	40:1 Wall Mount	4000 (275, 27.5)	100 (7, 0.7)	4.6 (17.4)	9.8 (290)	3/4 npt(f)	1 in	3/8 in	338026	312585
206515	10:1 Drum Mount	1800 (125, 12.5)	180 (12.5, 1.2)	3.0 (11.4)	6.4 (189)	1/2 npt(f)	1/2 in	3/4 in	—	306817

*Includes two outlet ports per unit

Accessories

Guns and Wands

- 247879 Replacement gun/wand
- 15T283 Brass/stainless spray gun
- 15T282 Stainless steel spray gun
- 15T279 32 inch stainless steel wand
- 15T280 10 inch stainless steel wand
- 247880 Gun stainless steel connections
- 247622 Gun and suction tube holder

Hoses

- 214959 1 in x 6 ft inlet hose
- 247878 3/8 in x 50 ft outlet hose: 4500 psi

Other

- 15T284 60 mesh inlet strainer with 1" NPT(f) connection
- 191635 10 mesh inlet strainer with 1" NPT(f) connection

Stainless Steel Tips

Part Number	Orifice Size in (mm)	Fan Width Angle at 40 psi (3 bar, 0.03 MPa)	Capacity at 1000 psi (68.9 bar, 6.89 MPa) GPM (lpm)
805534	0.020 (0.51)	40°	1.00 (3.78)
805538*	0.030 (0.76)	40°	1.50 (5.68)
805542	0.035 (0.89)	40°	1.75 (6.62)
805549*	0.045 (1.14)	25°	2.25 (8.52)
805561	0.060 (1.52)	25°	3.00 (11.36)
805566*	0.065 (1.65)	40°	3.25 (12.30)
805569	0.070 (1.78)	25°	3.50 (13.25)
805574	0.075 (1.91)	40°	3.75 (14.20)
805575*	0.080 (2.03)	0°	4.00 (15.14)
805584	0.090 (2.28)	15°	4.50 (17.03)
805587	0.100 (2.54)	0°	5.00 (18.93)

*Tips included with 12:1, 23:1, 30:1 and 45:1 Hydra-Clean pump packages.

Other orifice sizes and fan widths available from Graco, contact a sales representative for more information.

Dimensions

Wall Mount Package 247550

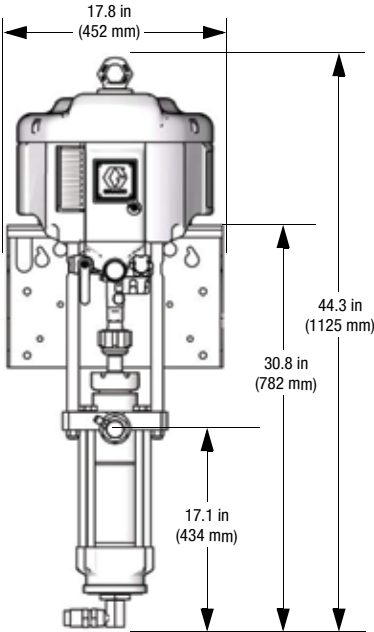

Refer to manual 312585 for additional package dimensions

Cart Mount Package 247549

