

Husky 716 Metal Pumps



Technical Specifications

Husky 716 Metal Pumps	Aluminum	Stainless Steel
Maximum fluid working pressure	100 psi (7 bar, 0.7 MPa)	100 psi (7 bar, 0.7 MPa)
Maximum free flow delivery*	16 gpm (61 lpm)	16 gpm (61 lpm)
Maximum pump speed	400 cpm	400 cpm
Displacement per cycle**	0.04 gallon (0.15 liter)	0.04 gallon (0.15 liter)
Maximum suction lift	15 ft (4.5 m) dry	15 ft (4.5 m) dry
Maximum size pumpable solids	0.09 in (2.5 mm)	0.09 in (2.5 mm)
Maximum ambient operating temperature***	180°F (82°C)	180°F (82°C)
Maximum diaphragm operating temperature***	Refer to page 5	Refer to page 5
Typical sound level at 70 psi air (4.9 bar, 0.49 MPa) air @ 200 cpm	74 dBA	74 dBA
Maximum air consumption	28 scfm (0.672 m3/min)	28 scfm (0.672 m3/min)
Air pressure operating range	30 to 100 psi (2.1 to 7 bar, 0.21 to 0.7 MPa)	30 to 100 psi (2.1 to 7 bar, 0.21 to 0.7 MPa)
Air inlet size	1/4 npt(f)	1/4 npt(f)
Air exhaust port size	3/8 npt(f)	3/8 npt(f)
Fluid inlet & outlet size	3/4 npt(f) or bspt(f)	3/4 npt(f) or bspt(f)
Weight	8.5 lb (3.9 kg)	18 lb (8.2 kg)
Wetted parts (in addition to ball, seat and diaphragm materials—which may vary by pump)	Aluminum, Stainless Steel, PTFE, Buna-N, Santoprene, Zinc-Plated Steel	Acetal, Polypropylene, Stainless Steel, Polyester, Santoprene, Fluoroelastomer, Nickel-Plated Brass, Epoxy-Coated Steel
Instruction manual	308981	308981

*Flow rates are with muffler and do not vary based on diaphragm material

**Displacement per cycle may vary based on suction condition, discharge head, air pressure and fluid type

***Actual pump performance may be affected by prolonged usage at temperature

Performance Charts

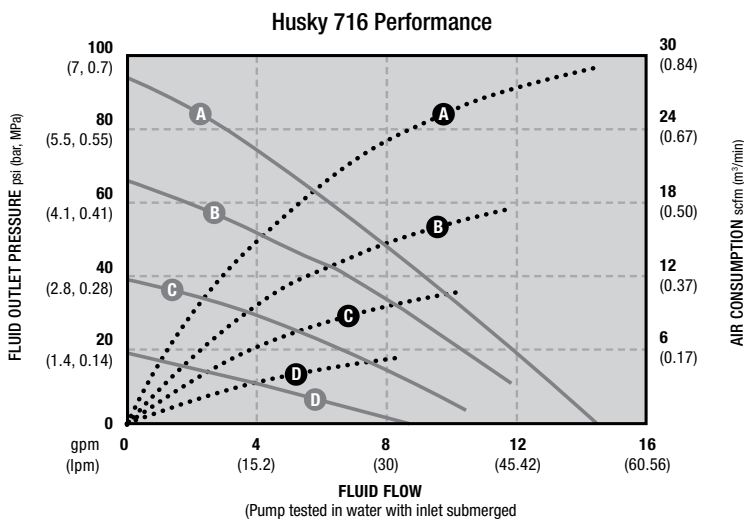

AIR PRESSURE	LEGEND
Ⓐ = at 100 psi (7 bar, 0.7 MPa)	Air Consumption.....
Ⓑ = at 70 psi (4.8 bar, 0.48 MPa)	Fluid Pressure ———
Ⓒ = at 40 psi (2.8 bar, 0.28 MPa)	
Ⓓ = at 20 psi (1.4 bar, 0.14 MPa)	

Husky 716 Metal Pumps

Dimensions

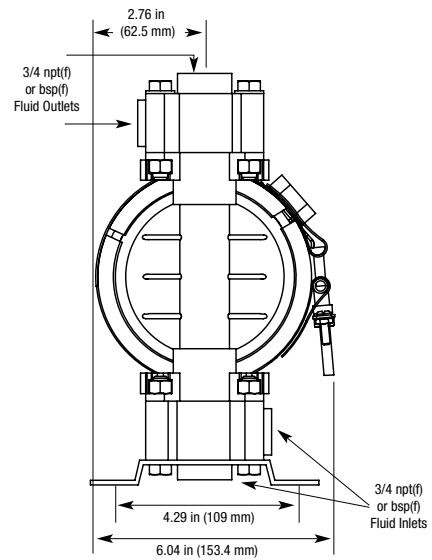
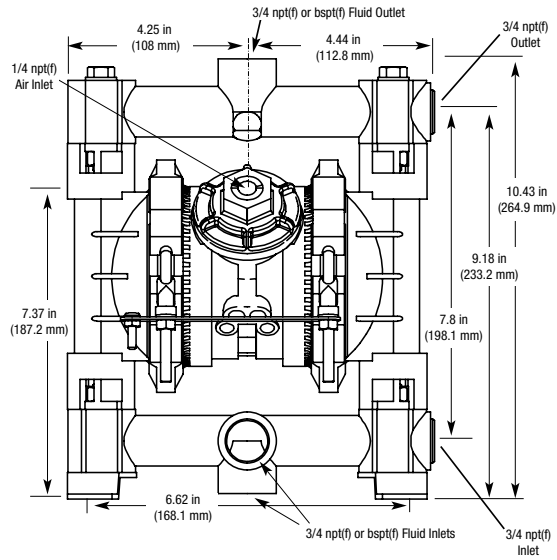

Typical System Drawings

Husky 716 Wall-Mount with Drum Feed

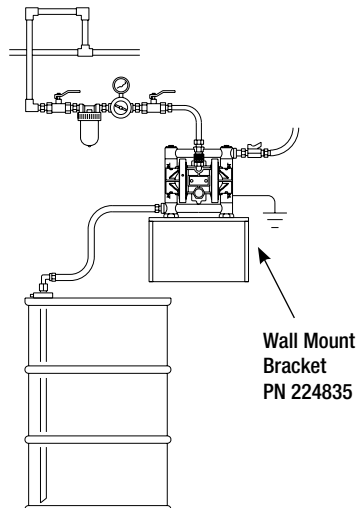

Husky 716 Drum-Mount with Siphon Feed

