



Legacy Pumps & Instruments LLC

PO Box 426, Mineral Wells, TX 76068-0426
 Phone 214-384-5303 or 817- 793-0485
 www.legacypumpsllc.com

Husky 307 Plastic Pumps

Air-Operated Double Diaphragm

Ordering Information

D **X** **X** **X** **X** **X**
 | | | | | |
 Diaphragm Pump Wetted Seats Balls/ Diaphragms
 Pump Size Parts Checks

PUMP SIZE (AIR MOTOR TYPE AND MATERIAL)	WETTED PARTS	SEATS	BALLS	DIAPHRAGM
3 = 3/8" (9.52 mm) Standard: polypropylene center section	1 = Acetal (npt) 2 = Poly (npt) A = Acetal (bsp) B = Poly (bsp)	2 = Acetal 3 = Stainless Steel 9 = Polypropylene	1 = PTFE 3 = SST 5 = TPE 6 = Santoprene 7 = Buna N	1 = PTFE 5 = TPE 6 = Santoprene 7 = Buna N

Popular Models

Material	Part Number (NPT Ported)		Part Number (BSP Ported)		Materials for Seats	Materials for Balls	Materials for Diaphragms	Fluid Kit	Air Kit	Air Control*
	Standard Air Valve	Remote Air Valve	Standard Air Valve	Remote Air Valve						
Acetal	D31211	NA	D3A211	NA	Acetal	PTFE	PTFE	D03211	239952	246946
	D31255	NA	D3A255	NA	Acetal	TPE	TPE	D03255	239952	246946
	D31277	NA	D3A277	NA	Acetal	Buna	Buna	D03277	239952	246946
	D31311	NA	D3A311	NA	Stainless Steel	PTFE	PTFE	D03311	239952	246946
Polypropylene	D32211	NA	D3B211	NA	Acetal	PTFE	PTFE	D03211	239952	246946
	D32255	NA	D3B255	NA	Acetal	TPE	TPE	D03255	239952	246946
	D32277	NA	D3B277	NA	Acetal	Buna	Buna	D03277	239952	246946
	D32311	NA	D3B311	NA	Stainless Steel	PTFE	PTFE	D03311	239952	246946
	D32366	NA	D3B366	NA	Stainless Steel	Santoprene	Santoprene	D03366	239952	246946
	D32911	NA	D3B911	NA	Polypropylene	PTFE	PTFE	D03911	239952	246946
	D32955	NA	D3B955	NA	Polypropylene	TPE	TPE	D03955	239952	246946
	D32966	NA	D3B966	NA	Polypropylene	Santoprene	Santoprene	D03966	239952	246946
	D32977	NA	D3B977	NA	Polypropylene	Buna	Buna	D03977	239952	246946

* Air control includes air regulator and filter with gauge (see drawing on page 13)

Husky 307 Plastic Pumps

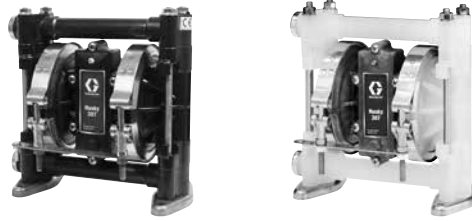

Technical Specifications

Husky 307 Plastic Pumps	Acetal	Polypropylene
Maximum fluid working pressure	100 psi (7 bar, 0.7 MPa)	100 psi (7 bar, 0.7 MPa)
Maximum free flow delivery*	7.0 gpm (26.5 lpm)	7.0 gpm (26.5 lpm)
Maximum pump speed	330 cpm	330 cpm
Displacement per cycle**	0.02 gallon (0.076 liter)	0.02 gallon (0.076 liter)
Maximum suction lift (D31255)	12 ft (3.7 m) dry	12 ft (3.7 m) dry
Maximum size pumpable solids	0.06 in (1.5 mm)	0.06 in (1.5 mm)
Maximum ambient operating temperature***	180°F (65.5°C)	150°F (65.5°C)
Maximum diaphragm operating temperature***	Refer to page 5	Refer to page 5
Typical sound level at 50 psi (3.5 bar, 0.35 MPa) air @ 50 cpm	75 dBa	75 dBa
Maximum air consumption	6 scfm (0.17 m3/min)	6 scfm (0.17 m3/min)
Air pressure operating range	20 to 100 psi (1.4 to 8.4 bar, 0.14 to 0.84 MPa)	20 to 100 psi (1.4 to 8.4 bar, 0.14 to 0.84 MPa)
Air inlet size	1/4 npt(f) or bspt(f)	1/4 npt(f) or bspt(f)
Fluid inlet & outlet size****	3/8 npt(f)	3/8 npt(f)
Weight	5.2 lb (2.4 kg)	4.75 lb (2.2 kg)
Wetted parts (in addition to ball, seat and diaphragm materials—which may vary by pump)	Acetal with Stainless Steel fibers, PTFE	Polypropylene, PTFE
Instruction manual	308553	308553

*Flow rates are with muffler and do not vary based on diaphragm material

**Displacement per cycle may vary based on suction condition, discharge head, air pressure and fluid type

***Actual pump performance may be affected by prolonged usage at temperature

Performance Chart

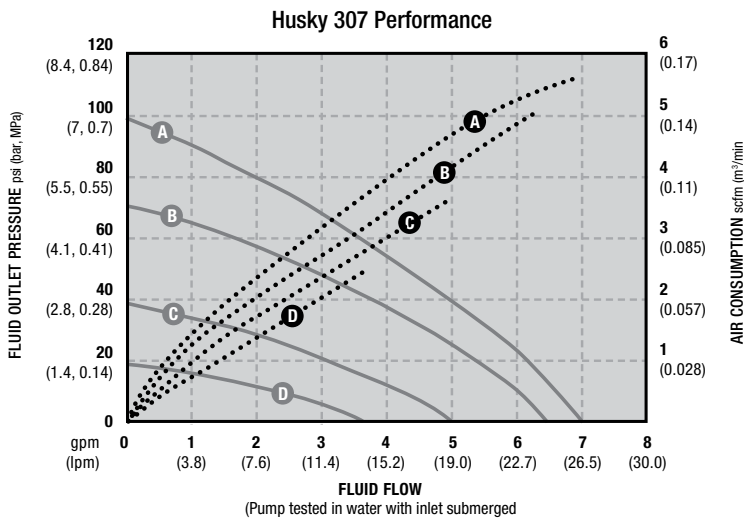

AIR PRESSURE	LEGEND
Ⓐ = at 100 psi (7 bar, 0.7 MPa)	Air Consumption.....
Ⓑ = at 70 psi (4.8 bar, 0.48 MPa)	Fluid Pressure ———
Ⓒ = at 40 psi (2.8 bar, 0.28 MPa)	
Ⓓ = at 20 psi (1.4 bar, 0.14 MPa)	

Dimensions

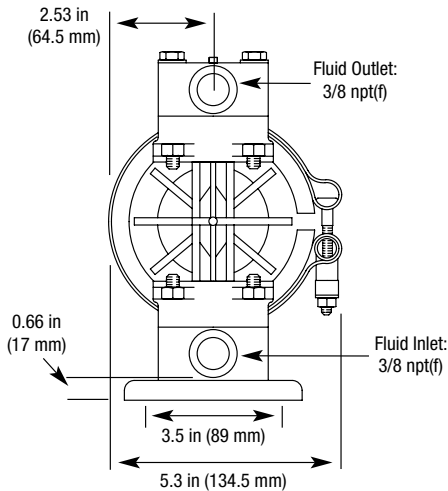
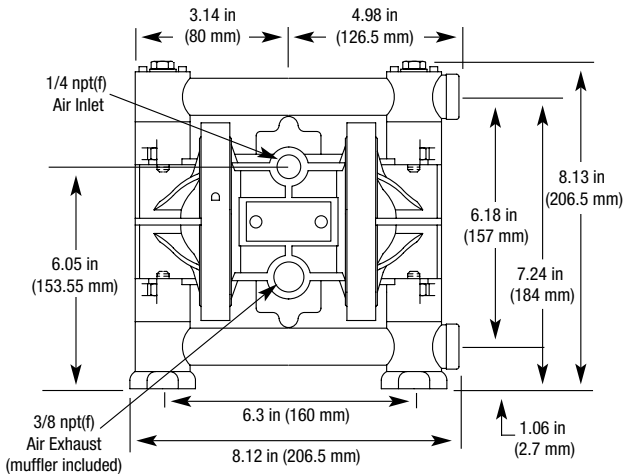

Typical System Drawings

Husky 307 Wall-Mount with Siphon Feed

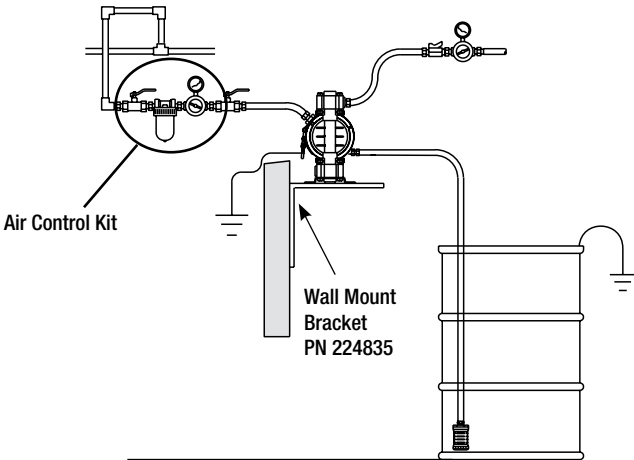

Husky 307 Drum-Mount with Siphon Feed

