



Legacy Pumps & Instruments LLC

PO Box 426, Mineral Wells, TX 76068-0426
 Phone 214-384-5303 or 817-793-0485
 www.legacypumpsllc.com

Husky 1590 Plastic Pumps Air-Operated Double Diaphragm

Ordering Information

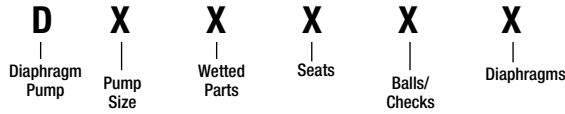

PUMP SIZE (AIR MOTOR TYPE AND MATERIAL)	WETTED PARTS	SEATS	BALLS	DIAPHRAGM
B = 1-1/2" (38.1 mm) Standard: aluminum center section	2 = Poly (flange)	3 = Stainless Steel	1 = PTFE	1 = PTFE
C = 1-1/2" (38.1 mm) Remote: aluminum center section	5 = PVDF (flange)	4 = Hardened SST	2 = Acetal	5 = TPE
T = 1-1/2" (38.1 mm) Standard: stainless steel center section		5 = TPE	4 = Hardened SST	6 = Santoprene
U = 1-1/2" (38.1 mm) Remote: stainless steel center section		6 = Santoprene	5 = TPE	7 = Buna N
		7 = Buna N	6 = Santoprene	8 = Fluoroelastomer
		8 = Fluoroelastomer	7 = Buna N	G = Geolast
		9 = Polypropylene	8 = Fluoroelastomer	
		A = PVDF	G = Geolast	
		G = Geolast		

Popular Models

Material	Part Number (ANSI-Flange)		Part Number (BSP Ported)		Materials for Seats	Materials for Balls	Materials for Diaphragms	Fluid Kit	Air Kit	Air Control**	
	Standard Air Valve	Remote* Air Valve	Standard Air Valve	Remote* Air Valve							
Standard Pumps with Aluminum Center Section											
Polypropylene	DB2311				Stainless Steel	PTFE	PTFE	DOC311	236273	246947	
	DB2377	DC2377			Stainless Steel	Buna	Buna	DOC377	236273	246947	
	DB2777	DC2777			Buna	Buna	Buna	DOC777	236273	246947	
	DB2888	DC2888			Fluoroelastomer	Fluoroelastomer	Fluoroelastomer	DOC888	236273	246947	
	DB2911	DC2911			Polypropylene	PTFE	PTFE	DOC911	236273	246947	
	DB2955				Polypropylene	TPE	TPE	DOC955	236273	246947	
	DB2966				Polypropylene	Santoprene	Santoprene	DOC966	236273	246947	
	DB2977				Polypropylene	Buna	Buna	DOC977	236273	246947	
	DB2988				Polypropylene	Fluoroelastomer	Fluoroelastomer	DOC988	236273	246947	
	DB29GG	DC29GG			Polypropylene	Geolast	Geolast	DOC9GG	236273	246947	
	PVDF	DB5311				Stainless Steel	PTFE	PTFE	DOC311	236273	246947
		DB5666				Santoprene	Santoprene	Santoprene	DOC666	236273	246947
		DB5811	DC5811			Fluoroelastomer	PTFE	PTFE	DOC811	236273	246947
DB5888		DC5888			Fluoroelastomer	Fluoroelastomer	Fluoroelastomer	DOC888	236273	246947	
DB5A11		DC5A11			PVDF	PTFE	PTFE	DOCA11	236273	246947	
DB5A88				PVDF	Fluoroelastomer	Fluoroelastomer	DOCA88	236273	246947		
Corrosion Resistant Pumps with Stainless Steel Center Section											
Polypropylene	DT2311	DU2311			Stainless Steel	PTFE	PTFE	DOC311	236273	246947	
	DT2341	DU2331			Hardened SST	Stainless Steel	PTFE	DOC331	236273	246947	
	DT2377	DU2377			Stainless Steel	Buna	Buna	DOC377	236273	246947	
	DT2888	DU2888			Fluoroelastomer	Fluoroelastomer	Fluoroelastomer	DOC888	236273	246947	
	DT2911	DU2911			Polypropylene	PTFE	PTFE	DOC911	236273	246947	
	DT2977	DU2977			Polypropylene	Buna	Buna	DOC977	236273	246947	
	DT2988	DU2988			Polypropylene	Fluoroelastomer	Fluoroelastomer	DOC988	236273	246947	
	PVDF	DT5311	DU5311			Stainless Steel	PTFE	PTFE	DOC311	236273	246947
DT5811		DU5811			Fluoroelastomer	PTFE	PTFE	DOC811	236273	246947	
DT5888		DU5888			Fluoroelastomer	Fluoroelastomer	Fluoroelastomer	DOC888	236273	246947	
DT5A11		DU5A11			PVDF	PTFE	PTFE	DOCA11	236273	246947	
DT5A88		DU5A88			PVDF	Fluoroelastomer	Fluoroelastomer	DOCA88	236273	246947	

*Requires CycleFlo or external valve control

** Air control includes air regulator and filter with gauge

Husky 1590 Plastic Pumps

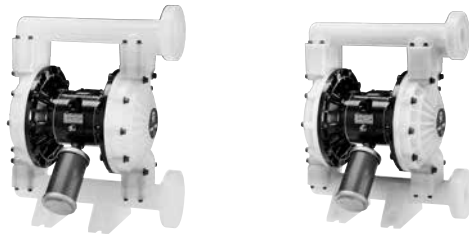

Technical Specifications

Husky 1590 Plastic Pumps	Polypropylene	PVDF
Maximum fluid working pressure	120 psi (8.4 bar, 0.84 MPa)	120 psi (8.4 bar, 0.84 MPa)
Maximum free flow delivery*	100 gpm (378.5 lpm)	100 gpm (378.5 lpm)
Maximum pump speed	200 cpm	200 cpm
Displacement per cycle**	0.5 gallon (1.96 liter)	0.5 gallon (1.96 liter)
Maximum suction lift (DB2366)	20 ft (6.1 m) dry	20 ft (6.1 m) dry
Maximum size pumpable solids	0.19 in (4.8 mm)	0.19 in (4.8 mm)
Maximum operating temperature***	150°F (65.5°C)	150°F (65.5°C)
Maximum diaphragm operating temperature***		
PTFE	220°F (104.4°C)	220°F (104.4°C)
Santoprene	180°F (82.2°C)	180°F (82.2°C)
Buna-N	180°F (82.2°C)	180°F (82.2°C)
TPE	150°F (65.5°C)	150°F (65.5°C)
Fluoroelastomer	250°F (121.1°C)	250°F (121.1°C)
Geolast	150°F (65.5°C)	150°F (65.5°C)
Typical sound level at 70 psi (4.9 bar, 0.49 MPa) air @ 125 cpm	77 dBa	77 dBa
Maximum air consumption	125 scfm (3.5 m3/min.)	125 scfm (3.5 m3/min.)
Air pressure operating range	20 to 120 psi (1.4 to 8.4 bar, 0.14 to 0.84 MPa)	20 to 120 psi (1.4 to 8.4 bar, 0.14 to 0.84 MPa)
Air inlet size	1/2 npt(f)	1/2 npt(f)
Fluid inlet & outlet size****	1-1/2 in (38.1 mm) ANSI-flange	1-1/2 in (38.1 mm) ANSI-flange
Weight	35 lb (16 kg)	49 lb (22 kg)
Weight with stainless steel center section	48.3 lb (21.9 kg)	62.3 lb (28.2 kg)
Instruction manual	308549	308549

* Flow rates are with muffler and do not vary based on diaphragm material

** Displacement per cycle may vary based on suction condition, discharge head, air pressure and fluid type

*** Actual pump performance may be affected by prolonged usage at temperature

Husky 1590 Plastic Pumps

Performance Charts

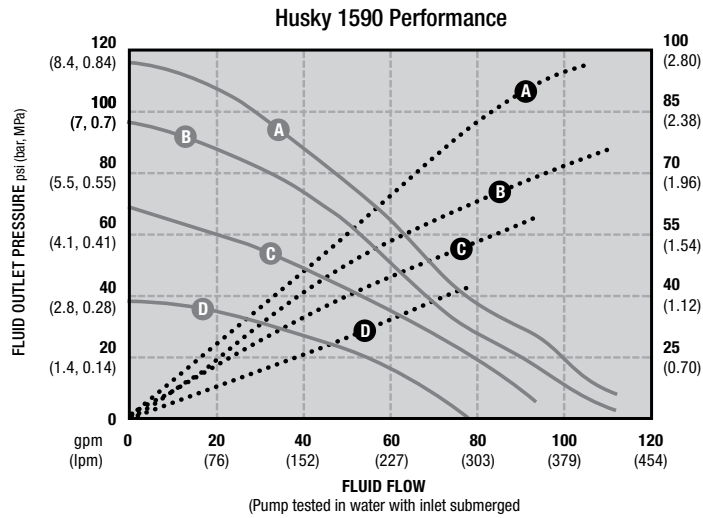

AIR PRESSURE	LEGEND
Ⓐ = at 120 psi (8.4 bar, 0.84 MPa)	Air Consumption.....
Ⓑ = at 100 psi (7 bar, 0.7 MPa)	Fluid Pressure ———
Ⓒ = at 70 psi (4.8 bar, 0.48 MPa)	
Ⓓ = at 40 psi (2.8 bar, 0.28 MPa)	

Dimensions

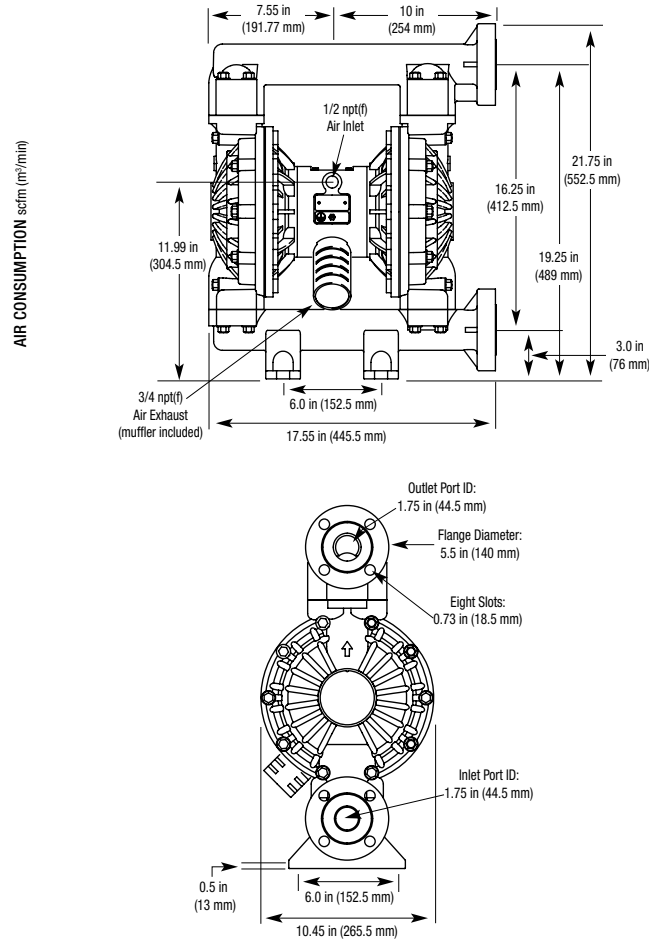

Typical System Drawings

Husky 1590 Above Ground Gravity Feed

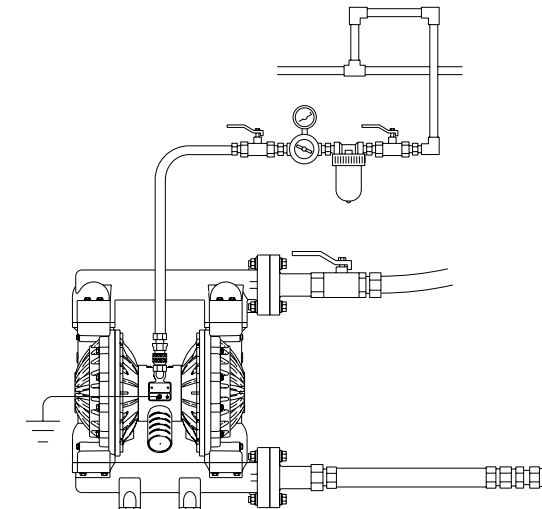

Husky 1590 Metal Pumps

Air-Operated Double Diaphragm

Ordering Information

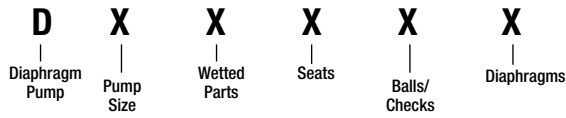

PUMP SIZE (AIR MOTOR TYPE AND MATERIAL)	WETTED PARTS	SEATS	BALLS	DIAPHRAGM
B = 1-1/2" (38.1 mm) Standard: aluminum center section	3 = Aluminum (npt)	3 = Stainless Steel	1 = PTFE	1 = PTFE
C = 1-1/2" (38.1 mm) Remote: aluminum center section	4 = Stainless Steel (npt)	4 = Hardened SST	2 = Acetal	5 = TPE
T = 1-1/2" (38.1 mm) Standard: stainless steel center section	C = Aluminum (bsp)	5 = TPE	4 = Hardened SST	6 = Santoprene
U = 1-1/2" (38.1 mm) Remote: stainless steel center section	D = Stainless Steel (bsp)	6 = Santoprene	5 = TPE	7 = Buna N
		7 = Buna N	6 = Santoprene	8 = Fluoroelastomer
		8 = Fluoroelastomer	7 = Buna N	G = Geolast
		9 = Polypropylene	8 = Fluoroelastomer	
		A = PVDF	G = Geolast	
		G = Geolast		

Popular Models

Material	Part Number (NPT Ported)		Part Number (BSP Ported)		Materials for Seats	Materials for Balls	Materials for Diaphragms	Fluid Kit	Air Kit	Air Control**
	Standard Air Valve	Remote* Air Valve	Standard Air Valve	Remote* Air Valve						
Standard Pumps with Aluminum Center Section										
Aluminum	DB3311	DC3311	DBC311	DCC311	Stainless Steel	PTFE	PTFE	D0B311	236273	246947
	DB3341		DBC341		Hardened SST	Stainless Steel	PTFE	D0B331	236273	246947
	DB3366	DC3366	DBC366	DCC366	Stainless Steel	Santoprene	Santoprene	D0B366	236273	246947
	DB3377	DC3377	DBC377	DCC377	Stainless Steel	Buna	Buna	D0B377	236273	246947
	DB3525	DC3525	DBC525	DCC525	TPE	Acetal	TPE	D0B525	236273	246947
	DB3555		DBC555		TPE	TPE	TPE	D0B555	236273	246947
	DB3666	DC3666	DBC666	DCC666	Santoprene	Santoprene	Santoprene	D0B666	236273	246947
	DB3777	DC3777	DBC777	DCC777	Buna	Buna	Buna	D0B777	236273	246947
	DB3888	DC3888	DBC888	DCC888	Fluoroelastomer	Fluoroelastomer	Fluoroelastomer	D0B888	236273	246947
	DB3GGG	DC3GGG	DBC3GGG	DCC3GGG	Geolast	Geolast	Geolast	D0BGGG	236273	246947
	DB3911		DBC911		Polypropylene	PTFE	PTFE	D0B911	236273	246947
	DB3977		DBC977		Polypropylene	Buna	Buna	D0B977	236273	246947
	Stainless Steel	DB4311	DC4311	DBD311	DCD311	Stainless Steel	PTFE	PTFE	D0B311	236273
DB4341			DBD341		Stainless Steel	Hardened SST	PTFE	D0B341	236273	246947
DB4377		DC4377	DBD377	DCD377	Stainless Steel	Buna	Buna	D0B377	236273	246947
DB4525			DBD525		TPE	Acetal	TPE	D0B525	236273	246947
DB4666		DC4666	DBD666	DCD666	Santoprene	Santoprene	Santoprene	D0B666	236273	246947
DB4777		DC4777	DBD777	DCD777	Buna	Buna	Buna	D0B777	236273	246947
DB4888		DC4888	DBD888	DCD888	Fluoroelastomer	Fluoroelastomer	Fluoroelastomer	D0B888	236273	246947
DB4GGG		DC4GGG	DBDGGG	DCDGGG	Geolast	Geolast	Geolast	D0BGGG	236273	246947
DB4911			DBD911		Polypropylene	PTFE	PTFE	D0B911	236273	246947
Corrosion Resistant Pumps with Stainless Steel Center Section										
Stainless Steel	DT4311	DU4311	DTD311	DUD311	Stainless Steel	PTFE	PTFE	D0B311	255061	246947
	DT4377	DU4377	DTD377	DUD377	Stainless Steel	Buna	Buna	D0B377	255061	246947
	DT4388	DU4388	DTD388	DUD388	Stainless Steel	Fluoroelastomer	Fluoroelastomer	D0B388	255061	246947
	DT4666	DU4666	DTD666	DUD666	Santoprene	Santoprene	Santoprene	D0B666	255061	246947
	DT4888	DU4888	DTD888	DUD888	Fluoroelastomer	Fluoroelastomer	Fluoroelastomer	D0B888	255061	246947
	DT4911	DU4911	DTD911	DUD911	Polypropylene	PTFE	PTFE	D0B911	255061	246947

*Requires CycleFlo or external valve control

** Air control includes air regulator and filter with gauge

Husky 1590 Metal Pumps

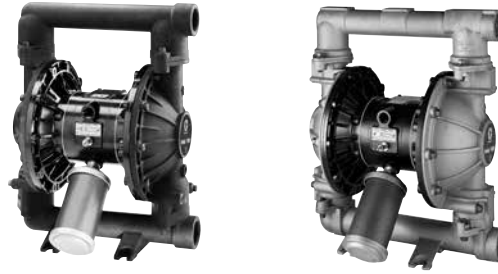

Technical Specifications

Husky 1590 Metal Pumps	Aluminum	Stainless Steel
Maximum fluid working pressure	120 psi (8.4 bar, 0.84 MPa)	120 psi (8.4 bar, 0.84 MPa)
Maximum free flow delivery*	100 gpm (378.5 lpm)	100 gpm (378.5 lpm)
Maximum pump speed	200 cpm	200 cpm
Displacement per cycle**	0.5 gallon (1.96 liter)	0.5 gallon (1.96 liter)
Maximum suction lift (DB2366)	20 ft (6.1 m) dry	20 ft (6.1 m) dry
Maximum size pumpable solids	0.19 in (4.8 mm)	0.19 in (4.8 mm)
Maximum operating temperature***	150°F (65.5°C)	150°F (65.5°C)
Maximum diaphragm operating temperature***		
PTFE	220°F (104.4°C)	220°F (104.4°C)
Santoprene	180°F (82.2°C)	180°F (82.2°C)
Buna-N	180°F (82.2°C)	180°F (82.2°C)
TPE	150°F (65.5°C)	150°F (65.5°C)
Fluoroelastomer	250°F (121.1°C)	250°F (121.1°C)
Geolast	150°F (65.5°C)	150°F (65.5°C)
Typical sound level at 70 psi (4.9 bar, 0.49 MPa) air @ 125 cpm	77 dBa	77 dBa
Maximum air consumption	125 scfm (3.5 m3/min.)	125 scfm (3.5 m3/min.)
Air pressure operating range	20 to 120 psi (1.4 to 8.4 bar, 0.14 to 0.84 MPa)	20 to 120 psi (1.4 to 8.4 bar, 0.14 to 0.84 MPa)
Air inlet size	1/2 npt(f)	1/2 npt(f)
Fluid inlet & outlet size****	1-1/2 npt(f) or bspt(f)	1-1/2 npt(f) or bspt(f)
Weight	33.5 lb (15.2 kg)	86 lb (40 kg)
Weight with stainless steel center section	n/a	98.8 lb (44.8 kg)
Instruction manual	308441	308441

*Flow rates are with muffler and do not vary based on diaphragm material

**Displacement per cycle may vary based on suction condition, discharge head, air pressure and fluid type

*** Actual pump performance may be affected by prolonged usage at temperature

Husky 1590 Metal Pumps

Performance Charts

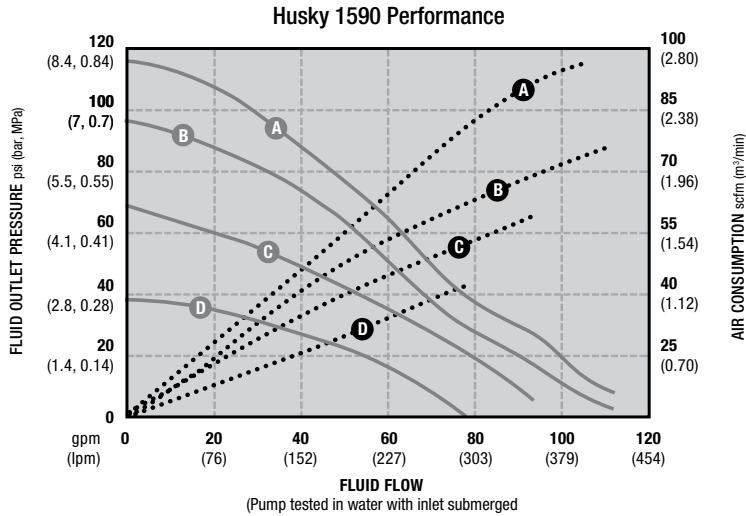

AIR PRESSURE	LEGEND
(A) = at 120 psi (8.4 bar, 0.84 MPa)	Air Consumption - -
(B) = at 100 psi (7 bar, 0.7 MPa)	Fluid Pressure - - - - -
(C) = at 70 psi (4.8 bar, 0.48 MPa)	
(D) = at 40 psi (2.8 bar, 0.28 MPa)	

Dimensions

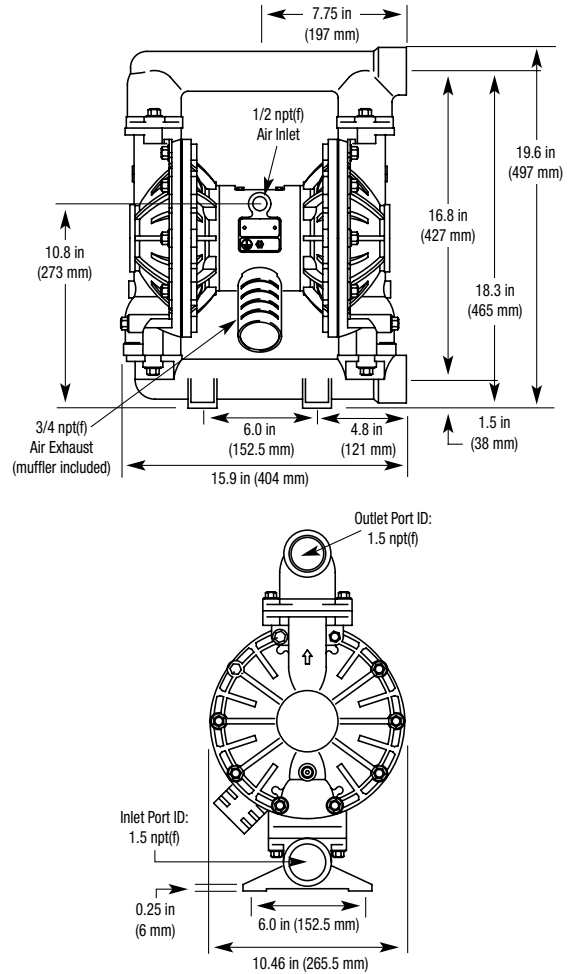

Refer to manual 308441 for additional dimensions

Typical System Drawings

Husky 1590 Above Ground Gravity Feed

