

A-100N STAR III[®] TANK

7, 15, 30 GALLON
Heavy Duty 0.30" wall

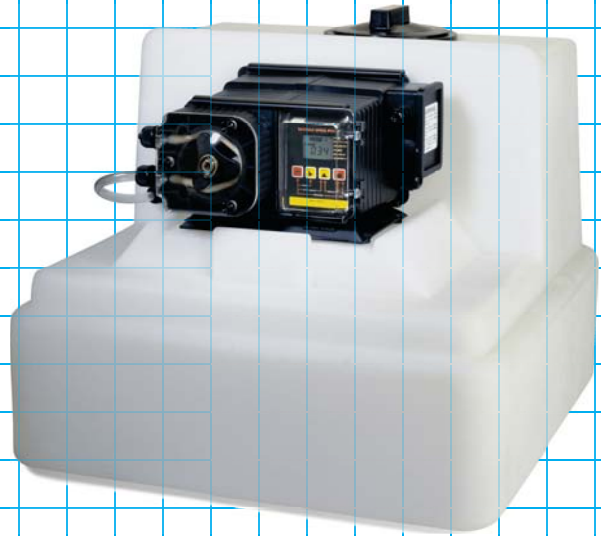

Features:

- Extra heavy 0.30" thick wall polyethylene with UV inhibitors.
- Ships complete with the A-100N pump model of your choice.
- 3 tank capacities to choose from: 7, 15, and 30 gallons.
- Molded-in threaded inserts and raised shelf for sturdy pump mounting.
- Lid positions include open, closed and vent.
- All necessary accessories are included.
- Convenient space saving rectangular shape.
- Raised off the floor for easy wash down.

Specifications:

Material:LLDPE
Capacity:7, 15, or 30 U.S. Gallons
Max. fluid temperature:130° F (54° C)
Max. ambient temperature: ..14° to 110° F/ -10° to 43° C
Approximate shipping wt: ...(includes A-100NV pump)
7 gallon units = 26 lb. (11.8 kg)
15 gallon units = 34 lb. (15.4 kg)
30 gallon units = 40 lb. (18.1 kg)

Materials of Construction:

Tank system only:

Tank:Natural Polyethylene (LLDPE)
Suction Strainer assembly:
Tubing:Clear PVC
Weight:Ceramic
Footvalve adapter & body: PVDF
Strainer screen:Polypropylene
Check Ball:Ceramic
Spring:Hastelloy C-276
Ball Seat O-ring:TFE/P (optional EP)
Static Seal O-ring:Viton[®] (optional EP)Natural
Lid:Polypropylene
Lid fasteners:Polypropylene

Blue-White

Industries, Ltd.

FLEXFLO® Peristaltic Metering Pumps

Dimensions:

	DIM 'A'	DIM 'B'	DIM 'C'	TANK SHIP WT.
7 GALLON TANK	20.00 (30)	18.50 (47)	18.50 (47)	14 LB. (6.3 Kg)
15 GALLON TANK	17.25 (44)	20.00 (51)	20.00 (51)	22 LB. (10 Kg)
30 GALLON TANK	27.50 (69)	20.00 (51)	20.00 (51)	28 LB. (12.7 Kg)

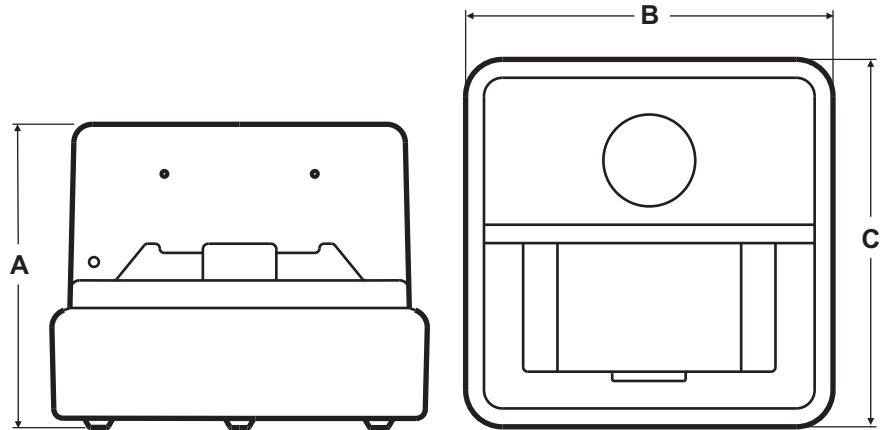

DIMENSIONS = INCH (CM)

Complete System Model Number Matrix:

MODEL A1N - - T15

Maximum Motor RPM

- 0 = 14 RPM
- 1 = 30 RPM
- 2 = 45 RPM
- 3 = 60 RPM

Power Supply

- 0 = 115V60Hz
- 1 = 220V50Hz
- 2 = 230V60Hz
- 8 = 240V50Hz

Output Control

- C = Analog timer, 5 sec. Cycle - 100% duty
- A = Analog timer, 60 sec. Cycle - 100% duty
- S = Analog timer, 60 sec. Cycle - 10% duty
- V = Digital speed control with external input
- F = Analog speed control
- E = Digital batch timer with external input
- Z = Proportional feed system - JBox/Cord
- X = No output control - fixed feed rate

Miscellaneous Options (not required)

- 1 = T140-6V injector replaces A-014HD-6A
- 2 = C-340V footvalve replaces C-342-6 strainer
- 5 = A-014HDK-6A injector PVDF
- T7 = 7 gallon chemical tank system
- T15 = 15 gallon chemical tank system
- T30 = 30 gallon chemical tank system

Tubing Connection Type

- T = Compression tube nuts
- Q = Push-on quick connect

Pump Tube Size and Material

- 1 = 1/4" OD Tygothane
- 2 = 3/8" OD Tygothane
- 3 = 7/16" OD Tygothane
- 4 = 1/4" OD Norprene
- 5 = 5/16" OD Viton
- 6 = 3/8" OD Norprene
- 7 = 7/16" OD Norprene

Tank Only Model Number:

- STAR3-7 = 7 gallon tank only
- STAR3-15 = 15 gallon tank only
- STAR3-30 = 30 gallon tank only

Blue-White
Industries, Ltd.



Legacy Pumps & Instruments LLC

PO Box 426, Mineral Wells, TX 76068-0426

Phone 214-384-5303 or 817-793-0485

www.legacypumpsllc.com

All trademarks are the property of their respective owners.

Technical data sheet #85000-045 rev.061305