

SONIC-PRO[®] S4 Transit Time Ultrasonic Flowmeter



Model S4X1CX020DG

- 1/2" thru 2" diameter Pipe Sizes
- Inline spool piece
- Advanced communications
- Data logging
- Process control relays
- 4-20mA and pulse outputs
- NEMA 4X (IP 66) washdown enclosure
- 2 Year warranty

💧 Liquid applications

NEMA 4X **CE** 

Applications:

- Ultra-Pure Water
- Wastewater
- Ground water
- Food and Beverage

Features:

- Ultrasonic Transit Time operation.
- Inline spool piece pipe fitting for easy installation.
- Non-intrusive, transducers do not touch the fluid.
- Special low power mode permits battery operation (limited features).
- High quality backlit LCD.
- Data logging to internal memory. User configurable to time interval, flow rate and total set-point triggers. 190,000 events can be downloaded to flash drive via USB.
- Isolated 4-20 mA output - fully configurable.
- 0 - 1000Hz Pulse output - fully configurable.
- Process control functions via two independently configurable 1 amp, form C relays. Configure to flow rate for high/low/range rate alarm or to flow total for either manual trigger batch operations or flow triggered batch operations.
- Optional communications include Industrial Ethernet, Modbus RTU, Modbus TCP, PROFIBUS DPV1, and PROFINET.

Specifications:

General Operation

Measuring Principle

Ultrasonic - Transit Time.

Fluid Types

Water to 5% (0 to 50,000 ppm) particulate.

Fluid Velocity Range

0.5 to 30 feet per second (0.15 to 9 meters per second)

Nominal Pipe Sizes

0.50, 0.75, 1.00, 1.50 and 2 inch IPS pipe sizes

Accuracy

+/-2% of rate > 1 ft/sec, +/-0.10 ft/sec < 1 ft/sec

Inline Pipe Fitting/ Transducer

Pipe Fitting/Transducer

NEMA 4X (IP66), High Density Polyethylene

Connection option A -

High Density Polyethylene, Female NPT threads

Maximum fluid temperature: 14°F to 160°F (-10°C to 71°C)

Maximum operating pressure: 300 PSI/g at 70°F

Connection option B -

316 Stainless Steel, Female NPT threads

Maximum fluid temperature: 14°F to 160°F (-10°C to 71°C)

Maximum operating pressure: 300 PSI/g at 70°F

Connection option C -

PVC, Female Slip

Maximum fluid temperature: 14°F to 140°F (-10°C to 60°C)

Maximum operating pressure: 300 PSI/g at 70°F

Connection option D -

316 Stainless Steel, 150# Flat Face Flange (without gaskets)

Maximum fluid temperature: 14°F to 160°F (-10°C to 71°C)

Maximum operating pressure: 300 PSI/g at 70°F

Cable - field replaceable

Shielded coaxial RG/U Type: 59. FEP jacket, black. RoHS Compliant

Connector: thermoplastic locking. NEMA 4X (IP66)

Available lengths: 10ft (3m), 25 ft. (7m), 50 ft. (15m), 100 ft. (30m)

**INLINE PIPE FITTING
TEMPERATURE VS PRESSURE**

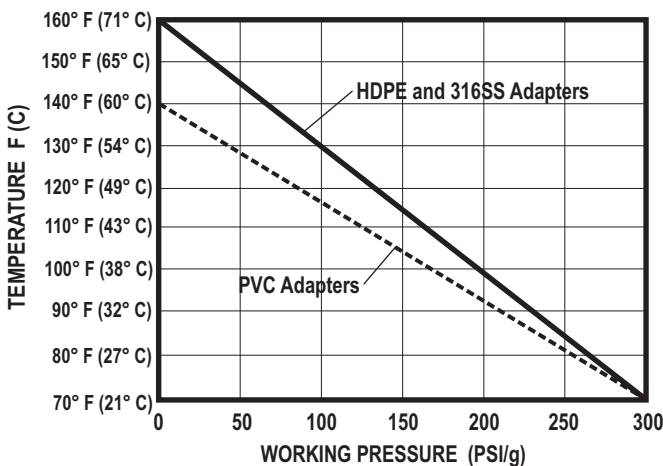

SPU (Signal Processing Unit)

Enclosure

NEMA 4X (IP66), Powder coated aluminum, SS clamps and hardware.

Dimensions: 7.24H x 6.69W x 3.11D inches (184H x 170W x 79D mm)

Weight 3.7 lb. (1.7 Kg.)

Mounting

Pipe fitting, wall or pipe (vertical or horizontal) mounting. Hardware included.

Power Requirements

15-28 VDC; 15 watts maximum

Operating Temperature

14°F to 140°F (-10°C to 60°C) **Storage:** -40°F to 158°F (-40°C to 70°C)

Display

VGA backlit LCD, UV resistant.

Simultaneous Rate and Total: 8 digit maximum

Decimal location configurable to 5 places.

Display Language

English

Keypad

Six-button positive action tactile switch keypad.

Security

Programmable 4-digit password.

Display Volume Units

Independently configurable Rate and Total display units in: U.S. Gallons, ounces, barrels (US liquid), barrels (US oil), cubic ft, acre ft, Imperial (British) gallons, liter, cubic meter, or user defined "custom" units.

Rate display in feet or meters per second.

Display Time Units

Seconds, minutes, hours, days.

Display/Output Response Time

1.0 second.

Flow Rate Display Averaging

Selectable: 0.50, 1.0, 2.5, 5.0 (default), 10.0 seconds.

Data Outputs

- Isolated 4-20 mA output - fully configurable, invertible
- 0-1000 Hz Pulse output - fully configurable, invertible

Data Logging

Date/time stamped flow rate and flow total data in FAT32 file format, easily imported into Excel. Configurable to trigger on time interval (1-999,999 sec), rate and/or total set-point values. Store up to 191,800 log events in the memory buffer, downloadable to flash memory via USB port.

Process Control

Two independently configurable relays.

Type: FORM C

Load capacity: 30V, 100mA max (ext. supplied)

- Configure to flow rate for high/low/range rate alarm. Programmable release values enable auto release or manual latching operation.
- Configure to flow total for automatically triggered, timed batch operations for proportional feed applications.

External Communications

Computer connection via optional **Communications Modules:**

- Industrial Ethernet/IP
- Modbus RTU
- Modbus TCP
- Profinet RT/IO
- Profibus DPV1

When equipped with a communications module, the following data transfer is possible:

1. Flow rate
2. Flow total
3. Fault/warning codes
4. Log data
5. CC1 relay status
6. CC2 relay status
7. Current fluid sound speed
8. Number of Goodness of Measurement boxes filled in
9. Analog output value (4-20 mA)
10. Frequency output value (0-1000 Hz)
11. Firmware version

Dimensions:

Sonic-Pro SPU

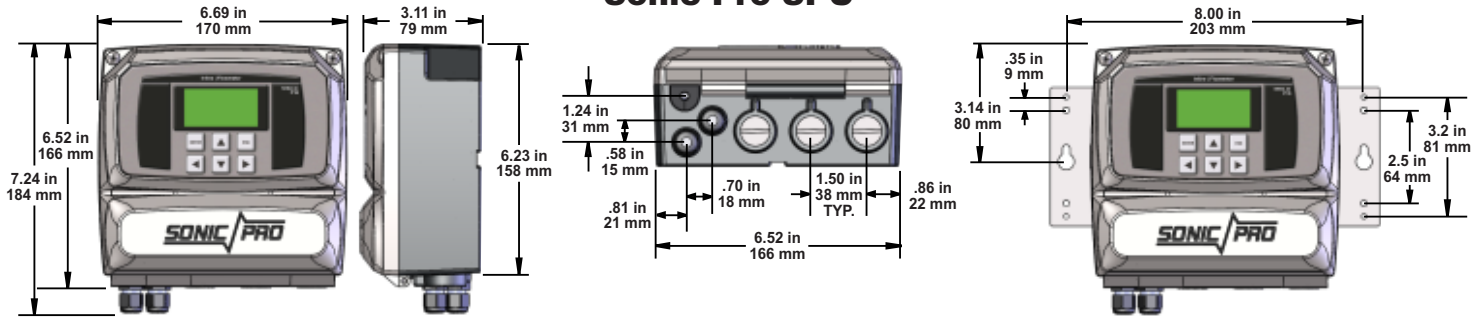

Sonic-Pro Inline Pipe Fittings

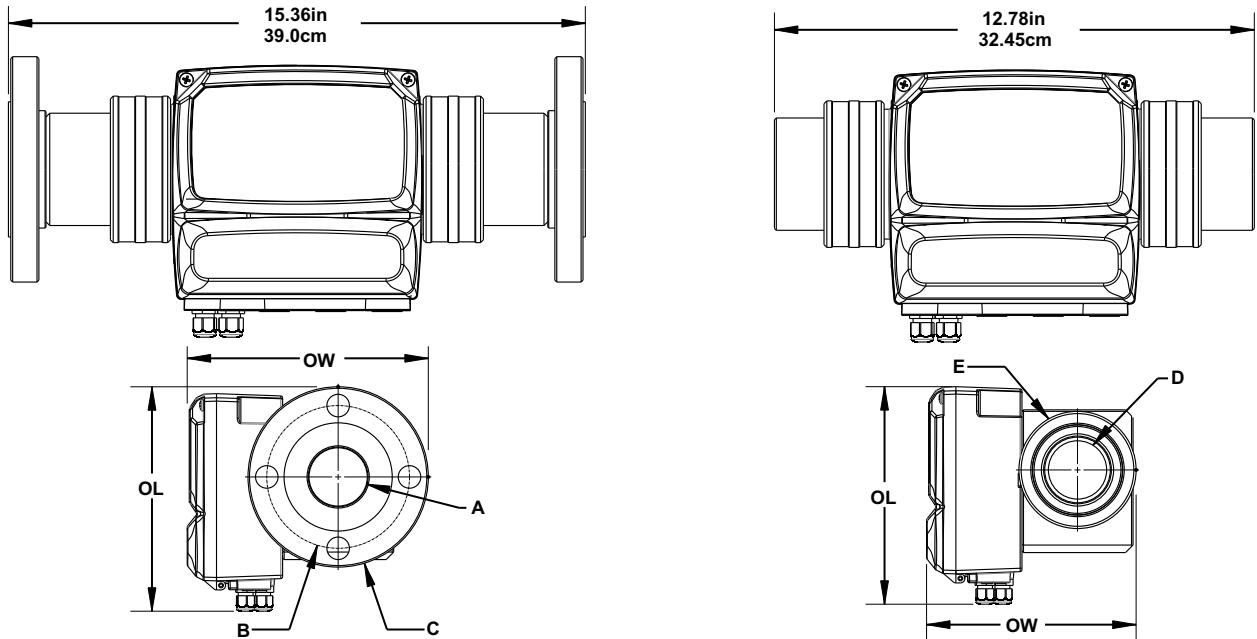

Flanged Fittings					
Pipe Size	OL	OW	A	B	C
2"	7.47in [18.97cm]	8.02in [20.38cm]	1.94in [4.93cm]	4.75in [12.07cm]	6.00in [15.24cm]
1.5"	7.24in [18.39cm]	7.35in [18.68cm]	1.50in [3.81cm]	3.88in [9.86cm]	5.00in [12.70cm]
1"	7.24in [18.39cm]	6.76in [17.18cm]	.96in [2.45cm]	3.12in [7.92cm]	4.25in [10.80cm]
.75"	7.24in [18.39cm]	6.45in [16.45cm]	.74in [1.88cm]	2.75in [6.99cm]	3.88in [9.86cm]
.5"	7.24in [18.39cm]	6.20in [15.75cm]	.55in [1.39cm]	2.38in [6.05cm]	3.50in [8.89cm]

NPT Fittings				
Pipe Size	OL	OW	D	E
2"	7.24in [18.39cm]	6.97in [17.71cm]	1.94in [4.93cm]	3.90in [9.91cm]
1.5"	7.24in [18.39cm]	6.53in [16.59cm]	1.50in [3.81cm]	3.33in [8.45cm]
1"	7.24in [18.39cm]	5.98in [15.18cm]	.96in [2.45cm]	2.75in [6.99cm]
.75"	7.24in [18.39cm]	5.90in [14.97cm]	.74in [1.88cm]	2.75in [6.99cm]
.5"	7.24in [18.39cm]	5.83in [14.80cm]	.55in [1.39cm]	2.75in [6.99cm]

Installation:

Fluid Requirements

The **Sonic-Pro series S4 Ultrasonic Flow Meter** can measure fluid flow in water. The **Sonic-Pro S4** meter measures fluid flow using the Transit Time method. The **Sonic-Pro S4** ultrasonic sound transducers are factory positioned for water. They do not touch the process fluid and there are no moving parts. This method of flow measurement is safe, non-intrusive and very easy to service.

To enable the sound waves to complete their circuit, the Transit Time measuring method requires relatively “clean” water. The maximum amount of particles should not exceed 0% to 5% (0 to 50,000 ppm).

Water that contains low concentrations of other chemicals, such as 5% sodium hypochlorite, may be acceptable provided the chemical does not change the speed that sound travels through the fluid more than approximately +/- 100 m/sec. The transducers are factory adjusted for a fluid with a sound speed of 1500 meters per second +/- 100 m/sec.

Minimum Straight Pipe Length Requirements

The Sonic-Pro’s sound wave beam is only affected by fluid that actually passes through the beam and therefore, the meter will not measure with high accuracy if the fluid velocity is not consistent across the entire pipe diameter. Flow disturbances such as pumps, elbows, tees, and valves in the flow stream can cause swirl patterns and vortices that will affect the measurement accuracy or disrupt flow measurement capability. Install the transducers on a straight run of pipe **as far as possible** from any disturbances. The distance required for high accuracy will depend on the type of disturbance.

Type of Disturbance	Straight Lengths of Pipe Required	
	Upstream from Transducers	Downstream from Transducers
Flange	5 x Nominal Pipe Size	5 x Nominal Pipe Size
Reducer	7 x Nominal Pipe Size	5 x Nominal Pipe Size
90° Elbow	10 x Nominal Pipe Size	5 x Nominal Pipe Size
Two 90° Elbows - 1 Direction	15 x Nominal Pipe Size	5 x Nominal Pipe Size
Two 90° Elbows - 2 Directions	20 x Nominal Pipe Size	5 x Nominal Pipe Size
Gate valve or Pump	25 x Nominal Pipe Size	5 x Nominal Pipe Size

Transducer Mounting Location

- The meter can be mounted on horizontal or vertical runs of pipe.
- Mounting anywhere around the diameter of vertical pipe is acceptable, however, the pipe must be completely full of fluid at all times.
- Back pressure is required on downward flows to ensure a full pipe.
- See the minimum straight length of pipe requirement chart above.

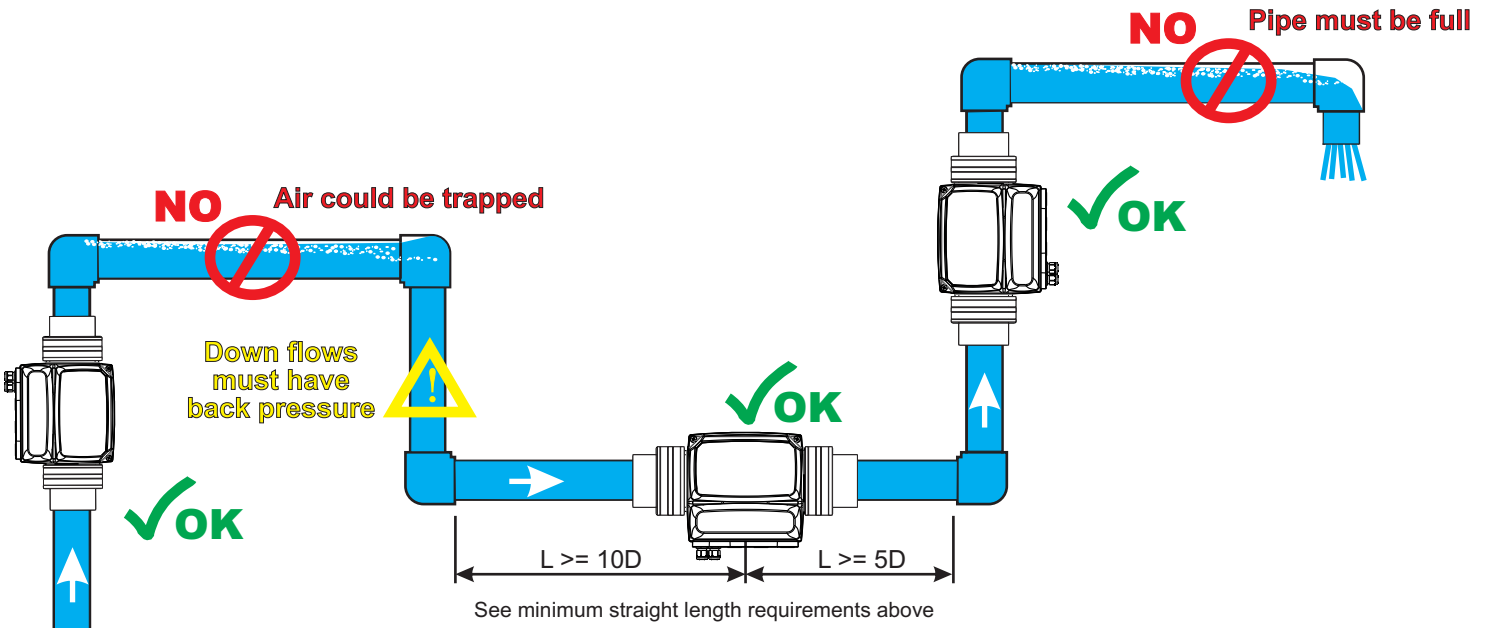

Display:

All Sonic-Pro S4 models allows full access to the configuration menus directly from the front panel.

Display

VGA backlit LCD displays flow rate, accumulated flow total, Goodness Of Measurement (GOM) indication, measured fluid sound speed

Display Language

English

Keypad

Six-button tactile switch keypad.

Security

Programmable 4-digit password.

Display Volume Units

Rate and Total display units in: U.S. Gallons, ounces, barrels (US liquid), barrels (US oil), cubic ft, acre ft, Imperial (British) gallons, liter, cubic meter, or user defined "custom" units. Rate display in feet or meters per second.

Display Time Units

Seconds, minutes, hours, days.



Output Signals:

All Sonic-Pro S4 models include both a 4-20mA analog and a 0-1000 Hz frequency output signal that is user configurable.

Communications Options:

Any S4 model can be equipped with any one of the following optional Communications Modules:

- Industrial Ethernet/IP
- Modbus RTU
- Modbus TCP
- Profinet RT/IO
- Profibus DPV1

When equipped with a communications module, the following data transfer is possible:

1. Flow rate
2. Flow total
3. Fault/warning codes
4. Log data
5. CC1 relay status
6. CC2 relay status
7. Current SOS
8. Number of Goodness of Measurement boxes filled in
9. Analog output value (4-20 mA)
10. Frequency output value (0-1000 Hz)
11. Firmware version

Data Logging:

All Sonic-Pro S4 models include data logging to a USB memory stick.

Each log entry includes: date/time, flow rate value, flow total value, and error codes in FAT32 file format easily imported into Excel. Configurable to trigger on time interval (1-999,999 sec), rate and/or total set-point values. Store up to 191,800 log entries in the memory buffer and download to an external flash memory via USB port.

Process Control:

All Sonic-Pro S4 models include two contact closure relays for rate and total flow volume alarms.

Each relay is can be configured to respond to changes in either the measured rate of flow or the accumulated total flow value. When assigned to monitor flow rate, high/low/range rate alarms are possible. When assigned to monitor accumulated total, automatically triggered, timed batch (proportional feed) operations are possible.

Type: FORM C. Load: 30V, 100mA max (ext. supplied)

Model Number Matrix:

Sonic-Pro S4 Part Number Matrix									
Signal Processing Unit (SPU) - Display									
S4	Sonic-Pro Base model								
Communications Options									
D	Industrial Ethernet/IP								
E	Modbus RTU								
F	Modbus TCP/IP								
G	PROFINET RT/IO								
H	PROFIBUS-DPV1								
X	Standard 4-20mA and High Speed Pulse output only								
Input Power (15 - 30 VDC required - all units include D cell battery pack, 4 D cell batteries are not included)									
0	Without power supply (customer supplies 15-30 VDC)								
1	U.S. 115VAC~50/60 / 15VDC plug-in transformer								
2	Europe 220VAC~50/60 / 15VDC plug-in transformer								
3	U.S. 230VAC~50/60 / 15VDC plug-in transformer								
Inline Pipe Fitting/Transducer									
C	Inline pipe fitting/transducer (see pipe size and material options below)								
X	Without inline pipe fitting/transducer								
Transducer Cable Length and Connection Type									
A	10 ft cable length - with field replaceable liquid-tight cable plug and socket								
B	25 ft cable length - with field replaceable liquid-tight cable plug and socket								
C	50 ft cable length - with field replaceable liquid-tight cable plug and socket								
D	100 ft cable length - with field replaceable liquid-tight cable plug and socket								
X	Display mounted directly on the inline pipe fitting/transducer - no transducer cables								
Z	Inline pipe fitting transducer only (no display) - without cables								
Inline Pipe Fitting/Transducer									
Fluid Sound Speed Working Range									
0	Water like fluids 1500 +/- 100 m/sec								
Nominal IPS Pipe Connection Size									
05	1/2"	07	3/4"	10	1"	15	1-1/2"	20	2"
Pipe Connection Type and Material									
A	F/NPT, HDPE	B	F/NPT, 316SS	C	Slip, PVC	D	Flange, 316SS		
Inline Body Material									
G	Polyethylene (HDPE)								
S4	D	1	C	A	0	07	A	G	Sample Part Number

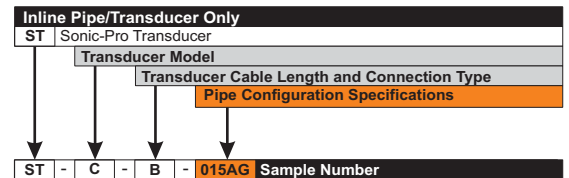

Legacy Pumps & Instruments LLC

PO Box 426, Mineral Wells, TX 76068-0426
 Phone 214-384-5303 or 817- 793-0485
 www.legacypumpsllc.com