

3" Metallic Models Pro-Series Pumps

3" Metallic Performance Specifications

Ratio:	1:1
Maximum Flow:	237-g.p.m. (897-l.p.m.)
Displacement per cycle:	2.65-Gallons (10.03-Liters)
Air Inlet: (Female)	3/4 - 14 N.P.T.F. - 1
Fluid Inlet:	3 - 8 N.P.T.F. - 1
	Rp 3 (3 - 11 BSP parallel)
Fluid Outlet:	3 - 8 N.P.T.F. - 1
	Rp 3 (3 - 11 BSP, parallel)
Max. operating pressure:	120-psi (8.3-bar)
Suspended solids max. dia.:	3/8-in. (9.5-mm)
Weight: lbs (kg)	
	6663X0-XXX-C 109.8 (49.8)
	6663X1-XXX-C 222.2 (100.8)
	6663X2-XXX-C 213.1 (96.7)
Maximum dry suction lift: ft (m)	17.6 (5.4)



67389 Muffler Kit (not shown)
included with pump

Ordering Menu

6663X	X	-	X	X	X	-	C
Center Body/ Threads	Fluid Caps/ Manifold Material		Seat Material	Ball Check Material	Diaphragm Material		
0 Aluminum, N.P.T.F.	0 Aluminum (steel hardware)		1 Aluminum	4 PTFE	4 PTFE / Santoprene		
2 Aluminum, BSP	1 Stainless steel (steel hardware)		9 Hytrel	C Hytrel	9 Hytrel		
	2 Cast iron (steel hardware)		E Santoprene	E Santoprene	B Santoprene		
			G Nitrile	G Nitrile	G Nitrile		

Accessories

Air Line Connection Kit* | Kit No. 66312

Kit includes Piggyback Filter/Regulator with gauge, pipe nipple and a 5-foot section of air hose.

Service Repair Kits | Kit No. 637434 (air section)

Kit No. 637433-XX (fluid section)

*Please note pumps are not included with these kits.

3" Metallic Dimensions and Flow Curves Pro-Series Pumps

3" Metallic Dimensions and Flow Charts

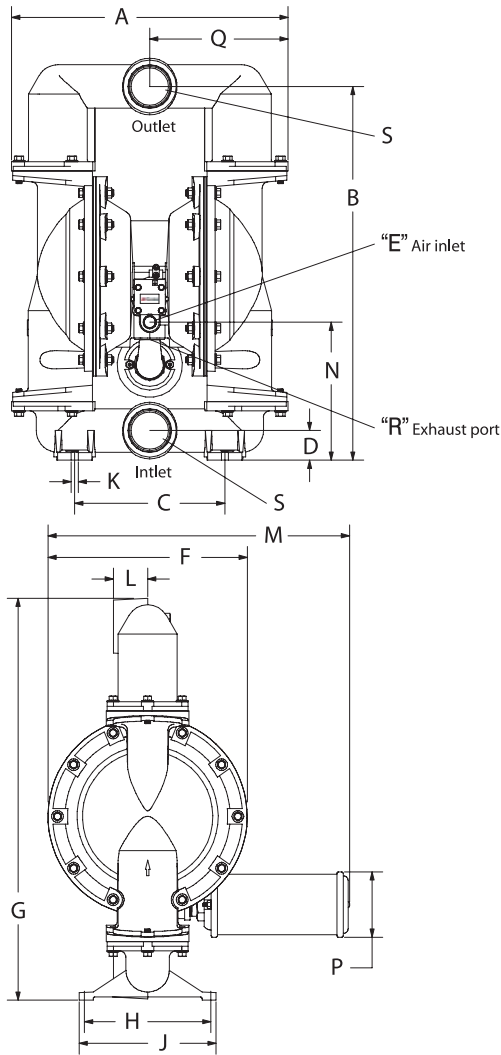

DIMENSIONS

A 22-7/32" (563.9 mm)	G 32-9/32" (819.8 mm)	N 11-3/32" (281.4 mm)
B 30" (762.0 mm)	H 10-5/32" (258.0 mm)	P 5-1/4" (133.4 mm)
C 12-1/16" (306.4 mm)	J 11" (279.4 mm)	Q 11-1/8" (281.9 mm)
D 2-3/8" (60.3 mm)	K 9/16" (14.3 mm)	R 1-1/4 - 11-1/2 N.P.T.F.-1
E 3/4 - 14 N.P.T.F. - 1	L 2-3/4" (69.9 mm)	S (see below)
F 16" (406.4 mm)	M 24-7/16" (620.7 mm)	

"S" Inlet / Outlet
 66630-XXX-C 3 - 8 N.P.T.F. - 1
 66632-XXX-C Rp 3 (3 - 11 BSP parallel)

NOTE: Dimensions are shown in inches and (mm), supplied for reference only and are typically rounded up to the nearest 1/16 inch.

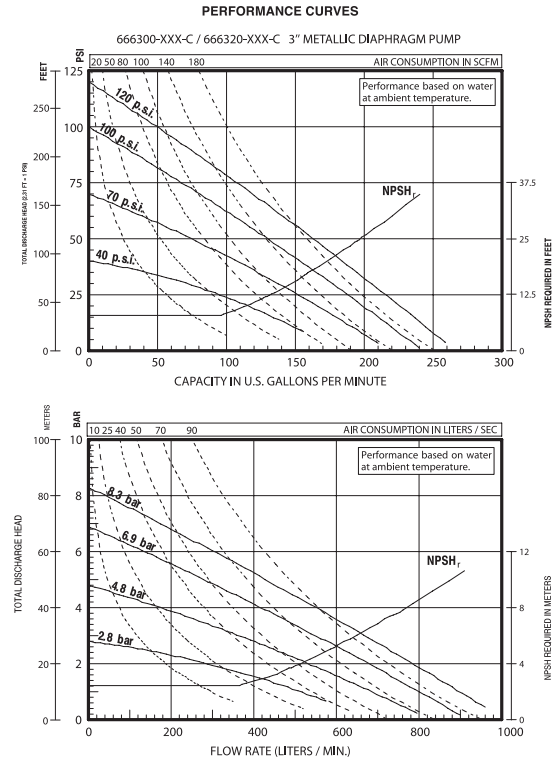

Refer to www.ingersollrandproducts.com for full size flow curves.

For additional information contact
 technical support at 1.800.483.4981

METALLIC