

3" Metallic Models OEM / Transfer Pumps

3" Metallic Performance Specifications

Ratio:	1:1		
Maximum GPM (LPM):	275 (1041)		
Displacement per cycle: @ 100 psi Gallons (Liters)	2.8 (10.6)		
Air Inlet: (Female)	3/4 - 14 N.P.T.F. - 1		
Fluid Inlet / Outlet (Female):	3" - 8 N.P.T.F. - 1 Rp 3 (3 - 11 BSP parallel)		
Max. operating pressure psi (bar):	120 (8.3)		
Suspended solids max. dia. in. (mm):	3/8 (9.5)		
Weight lbs (kg):	PX30A-XAX-XXX-C	129.5	(58.8)
	PX30A-XCX-XXX-C	216.6	(98.2)
	PX30A-XSX-XXX-C	228.8	(103.8)
	PX30A-XHX-XXX-C	249.8	(113.3)
	PX30R-XCX-XXX-C	242.3	(109.9)
	PX30R-XSX-XXX-C	253.3	(114.9)
	<i>Note: Add 40 lbs (18.2 kg) for stainless steel air motor section</i>		
Maximum dry suction lift ft (m):	14 (4.2)		
Sound Level:			

PSI	Cycles / Min	db(A)
70	50	83.0

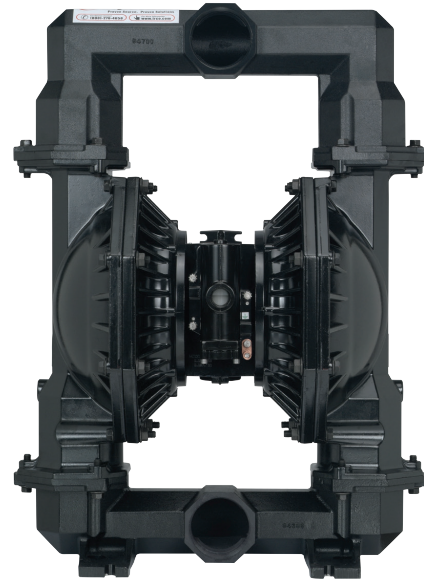

Ordering Menu

PX30	X	-	X	X	X	-	X	X	X	-	C	
Model Series	Center Section		Connection		Hardware		Seat Material		Diaphragm Material		Ball Material	
PD30 Standard Pump	A Aluminum		A N.P.T.F. Thread		P Plated Steel		A Santoprene		A Santoprene			
PE30 Electronic Interface Accessible Pump	R Polypropylene w/SS air Caps		B BSP Thread		S Stainless Steel		C Hytrel		C Hytrel			
	S Stainless Steel		F ANSI/DIN Flange			E Carbon Steel		G Nitrile		G Nitrile		
			Wetted Parts				F Aluminum		T PTFE/Santoprene		T PTFE/Santoprene	
			A Aluminum				G Nitrile		V Viton			
			C Cast Iron				H 440 Stainless Steel (Hard)					
			H Hastelloy-C ¹				K PVDF				A Santoprene	
			S Stainless Steel				L Hastelloy				C Hytrel	
							S 316 Stainless Steel				G Nitrile	
											T PTFE	
											V Viton	

Accessories*

Air Line Connection Kit | Kit No. 66109

Kit includes Piggyback Filter/Regulator with gauge, pipe nipple and a 5-foot section of air hose.

Diaphragm Failure Detection (DFD) | Kit No. 67237

Costly production downtime due to pump diaphragm failure and resulting (possibly hazardous) material leakage is a very real problem in many process operations. ARO Diaphragm Failure Detection is one simple, cost-effective way to get your pumps wired for preventive maintenance. (PE30X pump model is required)

Cycle Counter Kit | No. 67350-1

Like the odometer on your car, ARO's cycle sensing / cycle counter lets you know how many pump cycles have elapsed so you can be prepared to perform preventive maintenance. The cycle sensor is a cost-efficient way to save maintenance costs while keeping your pump on-line. (PE30X pump model is required)

- Service Repair Kits |** Kit No. 637369 (air motor for PX30R)
 Kit No. 637421 (air motor for PX30A and PX30S)
 Kit No. 637374-X (major air valve assembly)
 Kit No. 637303-XX (fluid section)

Continuous-Duty Muffler | No. 67263

Helps reduce possibility of pump freeze-over caused by moisture in air supply. Recommended for continuous-duty and high-flow applications. Muffler features large expansion chamber, permitting cold exhaust air to exit pump.

67263 Continuous-Duty Muffler would be used to replace 94810 Muffler that comes standard with pump.

*Please note pumps are not included with these kits.



