

2" Non-Metallic Models Pro-Series Pumps

2" Non-Metallic Performance Specifications

Ratio:	1:1
Maximum Flow:	145-g.p.m. (548.8-l.p.m.)
Displacement per cycle:	0.72-Gallons (2.7-Liters)
Air Inlet: (Female)	1/2 - 14 N.P.T.F. - 1
Fluid Inlet:	2" A.N.S.I./DIN Flange
Fluid Outlet:	2" A.N.S.I./DIN Flange
Max. operating pressure:	120-psi (8.3-bar)
Suspended solids max. dia.:	1/4-in. (6.4-mm)
Weight: lbs (kg)	6662A3-X-C 62 (28.1)

Note: Add 23-lbs (10.4-kg) for cast iron air motor section

Maximum dry suction lift: ft (m) 14 (4.27)

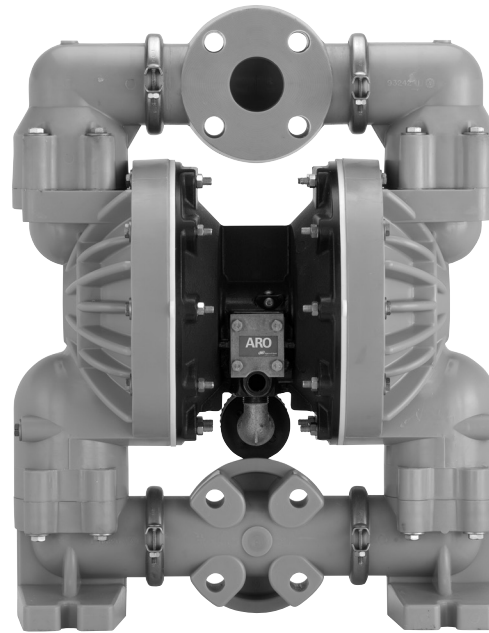

Ordering Menu

6662X	X	-	X	X	X	-	C
Center Body	Fluid Caps/ Manifold Material		Seat Material	Ball Check Material	Diaphragm Material		
A Aluminum B Cast Iron	3 Polypropylene Flange (3-piece manifold)	2 316 Stainless Steel 3 Polypropylene 8 400 Stainless Steel	3 Viton 4 PTFE 8 Polyurethane C Hytrel E Santoprene G Nitrile	3 Viton 4 PTFE / Santoprene 9 Hytrel B Santoprene G Nitrile			

Accessories

Air Line Connection Kit* | Kit No. 66084-1

Kit includes Piggyback Filter/Regulator with gauge, pipe nipple and a 5-foot section of air hose.

Service Repair Kits | Kit No. 637118-C (air section)

Kit No. 637165-XX (fluid section)

Flange Connection Kit | Kit No. 67080 (for 2" Non-Metallic Pumps)

For pumps with inlet/outlet flange manifolds. Kit meets ANSI specifications. Flange constructed of glass-filled polypropylene. Bolts, washers and nuts are stainless steel. Gasket is 4401 klinger synthetic fiber nitrile binder.



Flange Connection Kit
67080

*Please note pumps are not included with these kits.

2" Non-Metallic Dimensions and Flow Curves Pro-Series Pumps

2" Non-Metallic Dimensions and Flow Charts

All dimensions are given in inches and millimeters (mm).

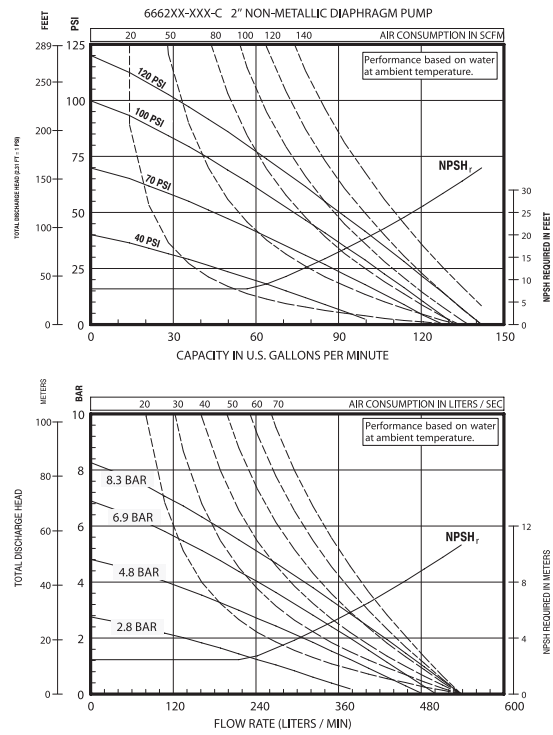
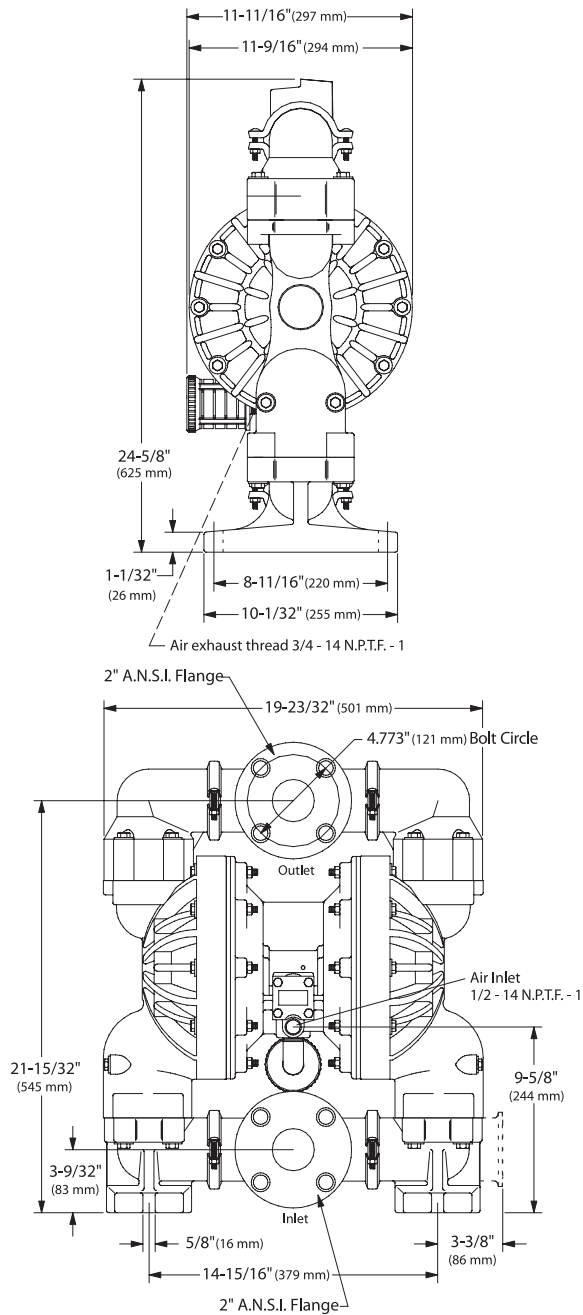

Refer to www.ingersollrandproducts.com for full size flow curves.

For additional information contact technical support at 1.800.483.4981

NON-METALLIC