

2" Non-Metallic Models OEM / Transfer Pumps

2" Non-Metallic Performance Specifications

Ratio:	1:1
Maximum GPM (LPM):	184 (696)
Displacement per cycle Gallons (Liters):	1.4 (5.3)
Air Inlet (Female):	3/4 - 14 N.P.T.
Fluid Inlet:	2" A.N.S.I./DIN flange (side)
Fluid Outlet:	2" A.N.S.I./DIN flange (side)
Max. operating pressure psi (bar):	120 (8.3)
Suspended solids max. dia. in. (mm):	1/4" (6.4)
Weight lbs (kg):	Polypropylene 85.3 (38.7) PVDF 110.9 (50.3)
Maximum dry suction lift ft (m):	14 (4.2)
Sound Level:	
	PSI Cycles / Min db(A)
	70 60 85.0



Ordering Menu

PX20	X	-	F	X	S	-	X	X	X
Model Series	Center Section		Connection	Wetted Parts	Hardware		Seat Material	Diaphragm Material	Ball Material
PD20 Standard Pump PE20 Electronic Interface Accessible Pump	E Conductive Polypropylene P Polypropylene		F 2" ANSI/DIN Flange (Side)	E Conductive Polypropylene K PVDF P Polypropylene	S Stainless Steel		K PVDF P Polypropylene	A Santoprene G Nitrile M Medical Grade Santoprene T PTFE/Santoprene V Viton	A Santoprene G Nitrile T PTFE V Viton

Accessories*

Air Line Connection Kit | Kit No. 66109

Kit includes Piggyback Filter/Regulator with gauge, pipe nipple and a 5-foot section of air hose.

Diaphragm Failure Detection (DFD) | Kit No. 67237

Costly production downtime due to pump diaphragm failure and resulting (possibly hazardous) material leakage is a very real problem in many process operations. ARO Diaphragm Failure Detection is one simple, cost-effective way to get your pumps wired for preventive maintenance. (PE20X pump model is required)

Cycle Counter Kit | Kit No. 67350-1

Like the odometer on your car, ARO's cycle sensing / cycle counter lets you know how many pump cycles have elapsed so you can be prepared to perform preventive maintenance. The cycle sensor is a cost-efficient way to save maintenance costs while keeping your pump on-line. (PE20X pump model is required)

Service Repair Kits | Kit No. 637369 (air motor for PX20P)

Kit No. 637373-XX (fluid section)

Kit No. 637374-X (major air valve assembly)

Continuous-Duty Muffler | Kit No. 67323

Helps reduce possibility of pump freeze-over caused by moisture in air supply. Recommended for continuous-duty and high-flow applications. Muffler features large expansion chamber, permitting cold exhaust air to exit pump.

Flange Connection Kit | Kit No. 67341-E20N

Use with non-metallic EXP pumps with the flange manifold option. Flange kits meet A.N.S.I. / DIN specifications. Flange constructed of glass-filled polypropylene. Bolts, washers and nuts are stainless steel.

*Please note pumps are not included with these kits.



2" Non-Metallic Dimensions and Flow Curves OEM / Transfer Pumps

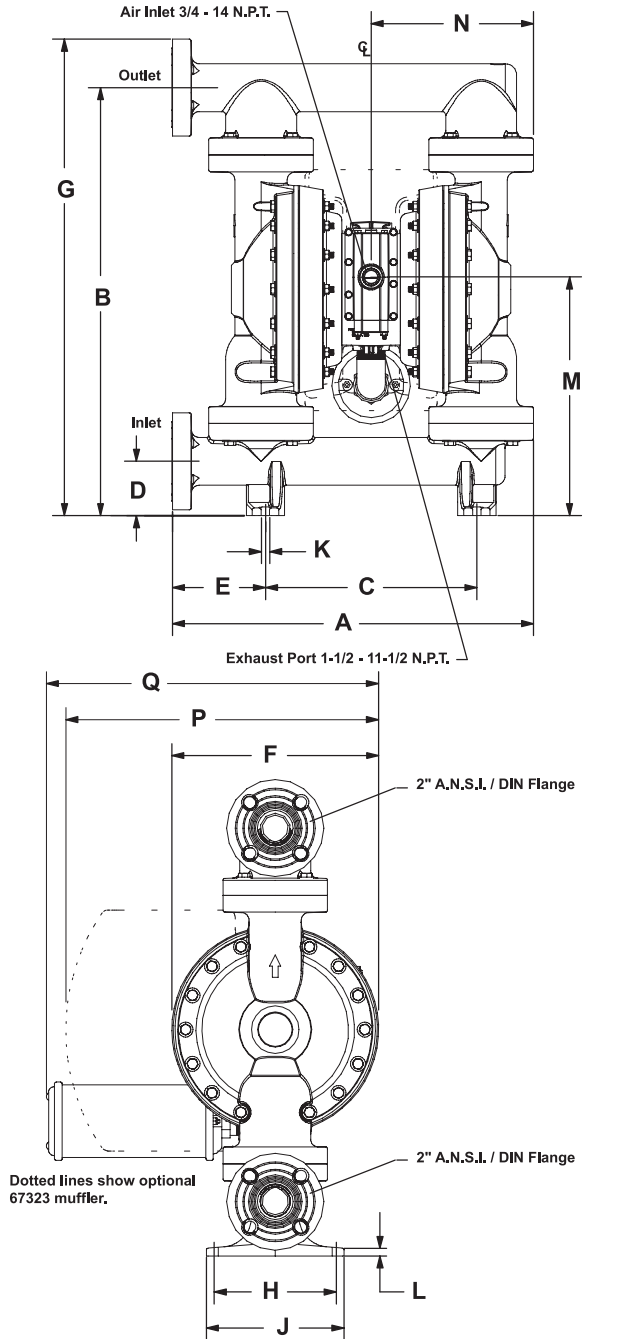

DIMENSIONS

A - 24-3/16" (614.3mm)	F - 13-7/8" (352.0mm)	L - 1/2" (12.7mm)
B - 28-21/32" (728.0mm)	G - 31-29/32" (810.5mm)	M - 16" (405.9mm)
C - 14-5/32" (360.0mm)	H - 8-3/16" (207.8mm)	N - 10-7/8" (276.2mm)
D - 3-5/8" (92.2mm)	J - 9-7/32" (234.2mm)	P - 20-31/32" (532.2mm)
E - 6-1/4" (158.3mm)	K - 9/16" (14.3mm)	Q - 22-9/32" (565.5mm)

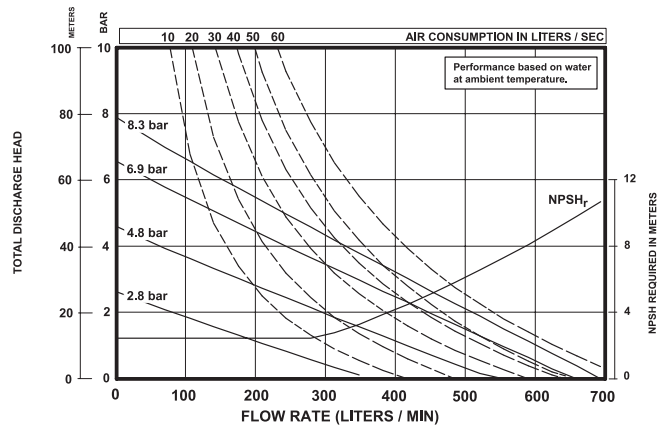
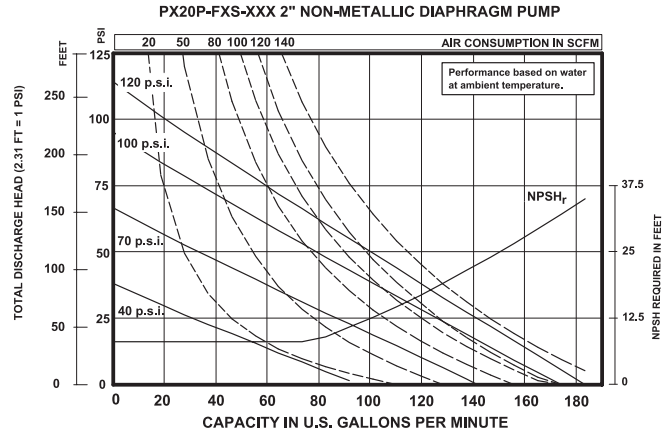

Refer to www.ingersollrandproducts.com for full size flow curves.

For additional information contact technical support at 1.800.483.4981

NON-METALLIC