

2" Metallic Models Pro-Series Pumps

2" Metallic Performance Specifications

Ratio:	1:1
Maximum Flow:	172-g.p.m. (651-l.p.m.)
Displacement per cycle:	1.4-Gallons (5.3-Liters)
Air Inlet: (Female)	3/4 - 14 N.P.T.F. - 1
Fluid Inlet:	2 - 11-1/2 N.P.T.F. - 1 Rp 2 (2 - 11 BSP, parallel)
Fluid Outlet:	2 - 11-1/2 N.P.T.F. - 1 Rp 2 (2 - 11 BSP, parallel)
Max. operating pressure:	120-psi (8.3-bar)
Suspended solids max. dia.:	1/4-in. (6.4-mm)
Weight: lbs (kg)	6662X0-XXX-C 65.2 (29.6) 6662X1-XXX-C 129.9 (58.9) 6662X2-XXX-C 124.3 (58.9)
Maximum dry suction lift: ft (m)	27.2 (8.3)



67389 Muffler Kit (not shown)
included with pump

Ordering Menu

6662X	X	-	X	X	X	-	C
Center Body/ Threads	Fluid Caps/ Manifold Material		Seat Material	Ball Check Material	Diaphragm Material		
5 Aluminum, N.P.T.F. 7 Aluminum, BSP	0 Aluminum (steel hardware) 1 Stainless steel (steel hardware) 2 Cast iron (steel hardware)		1 Aluminum 9 Hytrel E Santoprene G Nitrile	4 PTFE C Hytrel E Santoprene G Nitrile	4 PTFE / Santoprene 9 Hytrel B Santoprene G Nitrile		

Accessories

Air Line Connection Kit* | Kit No. 66312

Kit includes Piggyback Filter/Regulator with gauge, pipe nipple and a 5-foot section of air hose.

Service Repair Kits | Kit No. 637434 (air section)

Kit No. 637432-XX (fluid section)

*Please note pumps are not included with these kits.

2" Metallic Dimensions and Flow Curves Pro-Series Pumps

2" Metallic Dimensions and Flow Charts

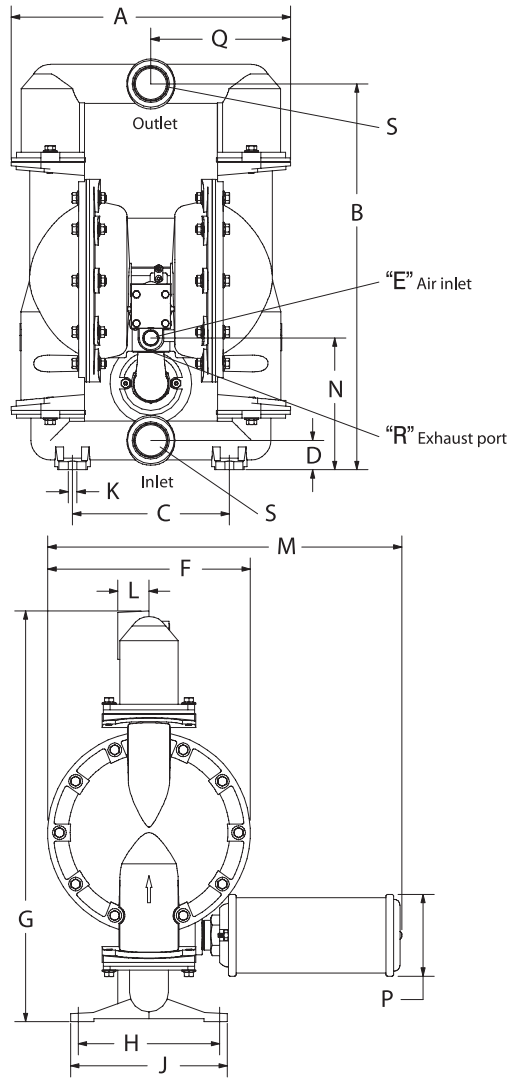

DIMENSIONS

A 17-15/16" (455.1 mm)	G 26-3/8" (669.5 mm)	N 8-15/32" (214.6 mm)
B 24-3/4" (628.7 mm)	H 9-1/16" (230.2 mm)	P 5-1/4" (133.4 mm)
C 10-1/16" (255.6 mm)	J 10-1/16" (255.6 mm)	Q 8-13/32" (227.6 mm)
D 1-7/8" (47.6 mm)	K 9/16" (14.3 mm)	R 1-1/4 - 11-1/2 N.P.T.F.-1
E 3/4 - 14 N.P.T.F. - 1	L 2" (50.8 mm)	S (see below)
F 13" (330.2 mm)	M 22-3/4" (577.3 mm)	

"S" Inlet / Outlet

66625-XXX-C 2 - 11-1/2 N.P.T.F. - 1

66627-XXX-C Rp 2 (2 - 11 BSP parallel)

NOTE: Dimensions are shown in inches and (mm), supplied for reference only and are typically rounded up to the nearest 1/16 inch.

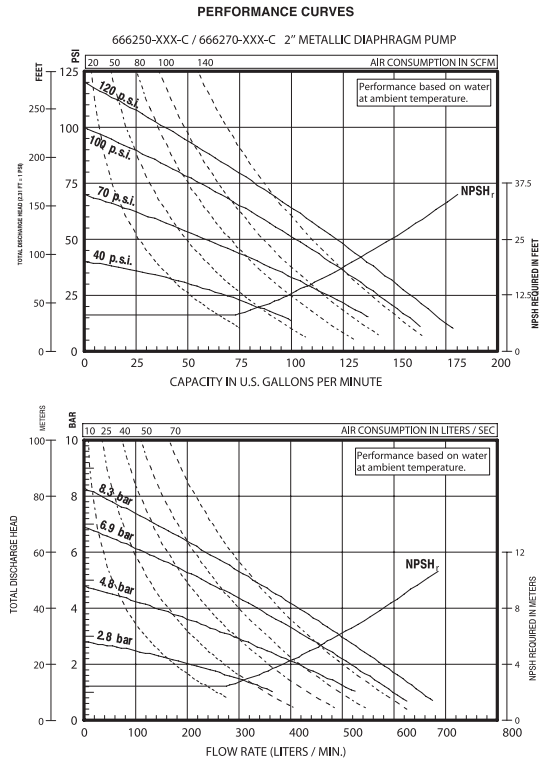

Refer to www.ingersollrandproducts.com for full size flow curves.

For additional information contact
technical support at 1.800.483.4981

METALLIC